

# Machinery Protection Systems

API STANDARD 670  
FOURTH EDITION, DECEMBER 2000



**Helping You  
Get The Job  
Done Right.<sup>SM</sup>**



# Machinery Protection Systems

**Downstream Segment**

API STANDARD 670  
FOURTH EDITION, DECEMBER 2000



**Helping You  
Get The Job  
Done Right.<sup>SM</sup>**

## SPECIAL NOTES

API publications necessarily address problems of a general nature. With respect to particular circumstances, local, state, and federal laws and regulations should be reviewed.

API is not undertaking to meet the duties of employers, manufacturers, or suppliers to warn and properly train and equip their employees, and others exposed, concerning health and safety risks and precautions, nor undertaking their obligations under local, state, or federal laws.

Information concerning safety and health risks and proper precautions with respect to particular materials and conditions should be obtained from the employer, the manufacturer or supplier of that material, or the material safety data sheet.

Nothing contained in any API publication is to be construed as granting any right, by implication or otherwise, for the manufacture, sale, or use of any method, apparatus, or product covered by letters patent. Neither should anything contained in the publication be construed as insuring anyone against liability for infringement of letters patent.

Generally, API standards are reviewed and revised, reaffirmed, or withdrawn at least every five years. Sometimes a one-time extension of up to two years will be added to this review cycle. This publication will no longer be in effect five years after its publication date as an operative API standard or, where an extension has been granted, upon republication. Status of the publication can be ascertained from the API Downstream Segment [telephone (202) 682-8000]. A catalog of API publications and materials is published annually and updated quarterly by API, 1220 L Street, N.W., Washington, D.C. 20005.

This document was produced under API standardization procedures that ensure appropriate notification and participation in the developmental process and is designated as an API standard. Questions concerning the interpretation of the content of this standard or comments and questions concerning the procedures under which this standard was developed should be directed in writing to the standardization manager, American Petroleum Institute, 1220 L Street, N.W., Washington, D.C. 20005. Requests for permission to reproduce or translate all or any part of the material published herein should also be addressed to the standardization manager.

API standards are published to facilitate the broad availability of proven, sound engineering and operating practices. These standards are not intended to obviate the need for applying sound engineering judgment regarding when and where these standards should be utilized. The formulation and publication of API standards is not intended in any way to inhibit anyone from using any other practices.

Any manufacturer marking equipment or materials in conformance with the marking requirements of an API standard is solely responsible for complying with all the applicable requirements of that standard. API does not represent, warrant, or guarantee that such products do in fact conform to the applicable API standard.

*All rights reserved. No part of this work may be reproduced, stored in a retrieval system, or transmitted by any means, electronic, mechanical, photocopying, recording, or otherwise, without prior written permission from the publisher. Contact the Publisher, API Publishing Services, 1220 L Street, N.W., Washington, D.C. 20005.*

## FOREWORD

This standard is based on the accumulated knowledge and experience of manufacturers and users of monitoring systems. The objective of the publication is to provide a purchase specification to facilitate the manufacture, procurement, installation, and testing of vibration, axial position, and bearing temperature monitoring systems for petroleum, chemical, and gas industry services.

The primary purpose of this standard is to establish minimum electromechanical requirements. This limitation in scope is one of charter as opposed to interest and concern. Energy conservation is of concern and has become increasingly important in all aspects of equipment design, application, and operation. Thus, innovative energy-conserving approaches should be aggressively pursued by the manufacturer and the user during these steps. Alternative approaches that may result in improved energy utilization should be thoroughly investigated and brought forth. This is especially true of new equipment proposals, since the evaluation of purchase options will be based increasingly on total life costs as opposed to acquisition cost alone. Equipment manufacturers, in particular, are encouraged to suggest alternatives to those specified when such approaches achieve improved energy effectiveness and reduced total life costs without sacrifice of safety or reliability.

This standard requires the purchaser to specify certain details and features. Although it is recognized that the purchaser may desire to modify, delete, or amplify sections of this standard, it is strongly recommended that such modifications, deletions, and amplifications be made by supplementing this standard, rather than by rewriting or by incorporating sections thereof into another complete standard.

API standards are published as an aid to procurement of standardized equipment and materials. These standards are not intended to inhibit purchasers or producers from purchasing or producing products made to specifications other than those of API.

API publications may be used by anyone desiring to do so. Every effort has been made by the Institute to assure the accuracy and reliability of the data contained in them; however, the Institute makes no representation, warranty, or guarantee in connection with this publication and hereby expressly disclaims any liability or responsibility for loss or damage resulting from its use or for the violation of any federal, state, or municipal regulation with which this publication may conflict.

Suggested revisions are invited and should be submitted to the standardization manager, American Petroleum Institute, 1220 L Street, N.W., Washington, D.C. 20005.

## **IMPORTANT INFORMATION CONCERNING USE OF ASBESTOS OR ALTERNATIVE MATERIALS**

Asbestos is specified or referenced for certain components of the equipment described in some API standards. It has been of extreme usefulness in minimizing fire hazards associated with petroleum processing. It has also been a universal sealing material, compatible with most refining fluid services.

Certain serious adverse health effects are associated with asbestos, among them the serious and often fatal diseases of lung cancer, asbestosis, and mesothelioma (a cancer of the chest and abdominal linings). The degree of exposure to asbestos varies with the product and the work practices involved.

Consult the most recent edition of the Occupational Safety and Health Administration (OSHA), U.S. Department of Labor, Occupational Safety and Health Standard for Asbestos, Tremolite, Anthophyllite, and Actinolite, 29 *Code of Federal Regulations* Section 1910.1001; the U.S. Environmental Protection Agency, National Emission Standard for Asbestos, 40 *Code of Federal Regulations* Sections 61.140 through 61.156; and the U.S. Environmental Protection Agency (EPA) rule on labeling requirements and phased banning of asbestos products (Sections 763.160-179).

There are currently in use and under development a number of substitute materials to replace asbestos in certain applications. Manufacturers and users are encouraged to develop and use effective substitute materials that can meet the specifications for, and operating requirements of, the equipment to which they would apply.

SAFETY AND HEALTH INFORMATION WITH RESPECT TO PARTICULAR PRODUCTS OR MATERIALS CAN BE OBTAINED FROM THE EMPLOYER, THE MANUFACTURER OR SUPPLIER OF THAT PRODUCT OR MATERIAL, OR THE MATERIAL SAFETY DATA SHEET.

# CONTENTS

	Page
1 GENERAL.....	1
1.1 Scope .....	1
1.2 Alternative Designs .....	1
1.3 Conflicting Requirements .....	1
2 REFERENCES .....	1
3 DEFINITIONS.....	2
4 GENERAL DESIGN SPECIFICATIONS .....	6
4.1 Component Temperature Ranges .....	6
4.2 Humidity .....	6
4.3 Shock .....	7
4.4 Chemical Resistance .....	7
4.5 Accuracy .....	7
4.6 Interchangeability .....	9
4.7 Scope of Supply and Responsibility .....	9
5 CONVENTIONAL HARDWARE.....	9
5.1 Radial Shaft Vibration, Axial Position, Phase Reference, Speed Sensing, and Piston Rod Drop Transducers .....	9
5.2 Accelerometer-Based Casing Transducers .....	14
5.3 Temperature Sensors .....	14
5.4 Monitor Systems .....	15
5.5 Wiring and Conduits .....	23
5.6 Grounding .....	26
5.7 Field-Installed Instruments .....	26
6 TRANSDUCER AND SENSOR ARRANGEMENTS .....	28
6.1 Location and Orientation .....	28
6.2 Mounting .....	34
6.3 Identification of Transducers and Temperature Sensors .....	36
7 INSPECTION, TESTING, AND PREPARATION FOR SHIPMENT .....	36
7.1 General .....	36
7.2 Inspection .....	37
7.3 Testing .....	37
7.4 Preparation for Shipment .....	37
7.5 Mechanical Running Test .....	37
7.6 Field Testing .....	38
8 VENDOR'S DATA.....	38
8.1 General .....	38
8.2 Proposals .....	42
8.3 Contract Data .....	43

APPENDIX A	MACHINERY PROTECTION SYSTEM DATA SHEETS . . . . .	45
APPENDIX B	TYPICAL RESPONSIBILITY MATRIX WORKSHEET . . . . .	53
APPENDIX C	ACCELEROMETER APPLICATION CONSIDERATIONS . . . . .	55
APPENDIX D	SIGNAL CABLE . . . . .	59
APPENDIX E	GEARBOX CASING VIBRATION CONSIDERATIONS . . . . .	61
APPENDIX F	FIELD TESTING AND DOCUMENTATION REQUIREMENTS . . . . .	63
APPENDIX G	CONTRACT DRAWING AND DATA REQUIREMENTS . . . . .	67
APPENDIX H	TYPICAL SYSTEM ARRANGEMENT PLANS . . . . .	71
APPENDIX I	SETPPOINT MULTIPLIER CONSIDERATIONS . . . . .	79
APPENDIX J	ELECTRONIC OVERSPEED DETECTION SYSTEM CONSIDERATIONS . . . . .	83

#### Tables

1	Machinery Protection System Accuracy Requirements . . . . .	8
2	Minimum Separation Between Installed Signal and Power Cables . . . . .	24
3A	Accelerometer Test Points (SI) . . . . .	42
3B	Accelerometer Test Points (Customary Units) . . . . .	42
D-1	Color Coding for Single-Circuit Thermocouple Signal Cable . . . . .	60
F-1	Tools and Instruments Needed to Calibrate and Test Machinery Protection Systems . . . . .	63
F-2	Data, Drawing, and Test Worksheet . . . . .	64
G-1	Typical Milestone Timeline . . . . .	67
G-2	Sample Distribution Record (Schedule) . . . . .	68
J-1	Recommended Dimensions for Speed Sensing Surface When Magnetic Speed Sensors are Used . . . . .	85
J-2	Recommended Dimensions for Non-Precision Speed Sensing Surface When Proximity Probe Speed Sensors are Used . . . . .	85
J-3	Recommended Dimensions for Precision-Machined Speed Sensing Surface When Proximity Probe Speed Sensors are Used . . . . .	85

#### Figures

1	Machinery Protection System . . . . .	4
2	Standard Monitor System Nomenclature . . . . .	5
3	Transducer System Nomenclature . . . . .	7
4	Typical Curves Showing Accuracy of Proximity Probe Channels . . . . .	10
5	Standard Probe and Extension Cable . . . . .	11
6	Standard Options for Proximity Probes and Extension Cables . . . . .	12
7	Standard Magnetic Speed Sensor With Removable (Non-Integral) Cable and Connector . . . . .	13
8	Piston Rod Drop Calculations . . . . .	19
9	Piston Rod Drop Measurement Using Phase Reference Transducer For Triggered Mode . . . . .	20
10	Typical Standard Conduit Arrangement . . . . .	24
11	Typical Standard Armored Cable Arrangement . . . . .	25
12	Inverted Gooseneck Trap Conduit Arrangement . . . . .	26
13	System Grounding (Typical) . . . . .	27
14	Standard Axial Position Probe Arrangement . . . . .	29
15	Typical Piston Rod Drop Probe Arrangement . . . . .	31
16	Typical Installations of Radial Bearing Temperature Sensors . . . . .	33
17	Typical Installations of Radial Bearing Temperature Sensors . . . . .	34
18	Typical Installation of Thrust Bearing Temperature Sensors . . . . .	35
19	Calibration of Radial Monitor and Setpoints for Alarm and Shutdown . . . . .	39



	Page
20 Calibration of Axial Position (Thrust) Monitor . . . . .	40
21 Typical Field Calibration Graph for Radial Vibration and Axial Position. . . . .	41
C-1 Typical Flush Mounted Accelerometer Details . . . . .	56
C-2 Typical Non-Flush Mounted Arrangement Details for Integral-Stud Accelerometer . . . . .	57
C-3 Typical Non-Flush Mounting Arrangement for Integral-Stud Accelerometer and Armored Extension Cable . . . . .	57
H-1 Typical System Arrangement for a Turbine With Hydrodynamic Bearings . . . . .	72
H-2 Typical System Arrangement for a Double-Helical Gear . . . . .	73
H-3 Typical System Arrangement for a Centrifugal Compressor or a Pump With Hydrodynamic Bearings. . . . .	74
H-4 Typical System Arrangement for an Electric Motor With Sleeve Bearings. . . . .	75
H-5 Typical System Arrangement for a Pump or Motor With Rolling Element Bearings . . . . .	76
H-6 Typical System Arrangement for a Reciprocating Compressor. . . . .	77
I-1 Setpoint Multiplication Example . . . . .	80
J-1 Overspeed Protection System . . . . .	83
J-2 Relevant Dimensions for Overspeed Sensor and Multi-Tooth Speed Sensing Surface Application Considerations . . . . .	84
J-4 Precision-Machined Overspeed Sensing Surface. . . . .	86



# Machinery Protection Systems

## 1 General

### 1.1 SCOPE

This standard covers the minimum requirements for a machinery protection system measuring radial shaft vibration, casing vibration, shaft axial position, shaft rotational speed, piston rod drop, phase reference, overspeed, and critical machinery temperatures (such as bearing metal and motor windings). It covers requirements for hardware (transducer and monitor systems), installation, documentation, and testing.

Note: A bullet (●) at the beginning of a paragraph indicates that either a decision is required or further information is to be provided by the purchaser. This information should be indicated on the datasheets (see Appendix A); otherwise, it should be stated in the quotation request or in the order.

### 1.2 ALTERNATIVE DESIGNS

The machinery protection system vendor may offer alternative designs. Equivalent metric dimensions and fasteners may be substituted as mutually agreed upon by the purchaser and the vendor.

### 1.3 CONFLICTING REQUIREMENTS

In case of conflict between this standard and the inquiry or order, the information included in the order shall govern.

## 2 References

2.1 The editions of the following standards, codes, and specifications that are in effect at the time of publication of this standard shall, to the extent specified herein, form a part of this standard. The applicability of changes in standards, codes, and specifications that occur after the inquiry shall be mutually agreed upon by the purchaser and the machinery protection system vendor.

#### API

RP 552	<i>Signal Transmission Systems</i>
RP 554	<i>Process Instrumentation and Control, Section 3, Alarm and Protective Devices</i>
Std 610	<i>Centrifugal Pumps for Petroleum, Heavy Duty Chemical and Gas Industry Services</i>
Std 612	<i>Special Purpose Steam Turbines for Petroleum, Chemical, and Gas Industry Services</i>

#### ANSI<sup>1</sup>

MC96.1	<i>Temperature Measurement Thermocouples</i>
--------	--

<sup>1</sup>American National Standards Institute, 11 West 42nd Street, New York, New York 10036.

#### ASME<sup>2</sup>

Y14.2M	<i>Line Conventions and Lettering</i>
PTC 20.2-1965	<i>Overspeed Trip Systems for Steam Turbine-Generator Units</i>

#### CENELEC<sup>3</sup>

EN50082-2	<i>Electromagnetic Compatibility Generic Immunity Standard. Part 2: Industrial Environment</i>
-----------	--

#### DIN<sup>4</sup>

EN 50022	<i>Low voltage switchgear and controlgear for industrial use; mounting rails, top hat rails, 35 mm wide for snap-on mounting of equipment.</i>
----------	--

#### IEC<sup>5</sup>

584-1	<i>Thermocouples, Part I: Reference Tables</i>
-------	--

#### IPCEA<sup>6</sup>

S-61-402	<i>Thermoplastic-Insulated Wire and Cable for the Transmission and Distribution of Electrical Energy</i>
----------	--

#### ISA<sup>7</sup>

S12.1	<i>Definitions and Information Pertaining to Electrical Instruments in Hazardous (Classified) Locations</i>
S12.4	<i>Instrument Purging for Reduction of Hazardous Area Classification</i>
S84.01	<i>Application of Safety Instrumented Systems for the Process Industries</i>

#### Military Specifications<sup>8</sup>

MIL-C-39012-C	<i>Connectors, Coaxial, Radio Frequency, General Specification for</i>
MIL-C-39012/5F	<i>Connectors, Plug, Electrical, Coaxial, Radio Frequency, [Series N (Cabled) Right Angle, Pin Contact, Class 2]</i>

<sup>2</sup>American Society of Mechanical Engineers, 22 Law Drive, Box 2300, Fairfield, New Jersey 07007-2300.

<sup>3</sup>European Committee for Electrotechnical Standardization, Rue de Stassart, 35, B - 1050 Brussels.

<sup>4</sup>Deutsches Institut fuer Normung e.V., Burggrafenstrasse 6, Postfach 11 07, 10787 Berlin, Germany.

<sup>5</sup>International Electrotechnical Commission, 1 Rue de Varembe, Geneva, Switzerland.

<sup>6</sup>Insulated Power Cable Engineers Association, 283 Valley Road, Montclair, New Jersey 07042.

<sup>7</sup>Instrument Society of America, P.O. Box 12277, Research Triangle Park, North Carolina 27709.

<sup>8</sup>Available from Naval Publications and Forms Center, 5801 Tabor Avenue, Philadelphia, Pennsylvania 19120.

MIL-STD-883B	<i>Tests, Methods, and Procedures for Micro-Electronics</i>
NEMA <sup>9</sup>	
250	<i>Enclosures for Electrical Equipment (1000 Volts Maximum)</i>
WC 5	<i>Thermoplastic-Insulated Wire and Cable for the Transmission and Distribution of Electrical Energy</i>
NFPA <sup>10</sup>	
70	<i>National Electrical Code</i>
496	<i>Purged and Pressurized Enclosures for Electrical Equipment</i>
OSHA <sup>11</sup>	
Form 20	<i>Material Safety Data Sheet</i>
Schneider Electric <sup>12</sup>	
PI-MBUS-300	<i>Modbus® Protocol Reference Guide</i>

**2.2** The standards, codes, and specifications of the American Iron and Steel Institute (AISI)<sup>13</sup> also form part of this standard.

**2.3** The purchaser and the machinery protection system vendor shall mutually determine the measures that must be taken to comply with any governmental codes, regulations, ordinances, or rules that are applicable to the equipment.

### 3 Definitions

Terms used in this standard are defined as follows:

**3.1 accelerometer:** A piezoelectric sensor containing integral amplification with an output proportional to acceleration.

**3.2 accelerometer cable:** An assembly consisting of a specified length of cable and mating connectors. Both the cable and the connectors must be compatible with the particular accelerometer and (when used) intermediate termination.

**3.3 accuracy:** The degree of conformity of an indicated value to a recognized accepted standard value or ideal value.

**3.4 active magnetic speed sensor:** A magnetic speed sensor that requires external power and provides a conditioned

(that is, square wave) output. Typical excitation is between +5 to +30 Vdc.

**3.5 active (normal) thrust direction:** The direction of a rotor axial thrust load expected by the machinery vendor when the machinery is operating under normal running conditions.

**3.6 alarm (alert) setpoint:** A preset value of a parameter at which an alarm is activated to warn of a condition that requires corrective action.

**3.7 alarm/shutdown/integrity logic:** The function of a monitor system whereby the outputs of the signal processing circuitry are compared against alarm or shutdown setpoints and circuit fault criteria. Violations of these setpoints or circuit fault criteria result in alarm or shutdown status conditions in the monitor system. These status conditions may be subjected to preset time delays or logical voting with other status conditions, and are then used to drive the system output relays and status indicators and outputs.

**3.8 bench test:** A factory acceptance test performed within the testing range (see 4.1 and Table 1).

**3.9 best fit straight line:** The line drawn through the actual calibration curve where the maximum plus or minus deviations are minimized and made equal.

**3.10 blind monitor system:** Does not contain an integral display. A blind monitor system is permitted as a “when specified” option of this standard provided it is supplied with at least one dedicated, continuous, non-integral display. The blind monitor provides certain minimal integral status indication independently of any non-integral displays (see 5.4.1.6.b).

**3.11 buffered output:** An unaltered, analog replica of the transducer input signal that preserves amplitude, phase, frequency content, and signal polarity. It is designed to prevent a short circuit of this output to monitor system ground from affecting the operation of the machinery protection system. The purpose of this output is to allow connection of vibration analyzers, oscilloscopes, and other test instrumentation to the transducer signals.

**3.12 channel:** The monitor system components associated with a single transducer. The number of channels in a monitor system refers to the number of transducer systems it can accept as inputs.

**3.13 channel pair:** Two associated measurement locations (such as the X and Y proximity probes at a particular radial bearing or the two axial proximity probes at a particular thrust bearing).

**3.14 circuit fault:** A machinery protection system circuit failure that adversely affects the function of the system.

<sup>9</sup>National Electrical Manufacturers Association, 2101 L Street, N.W., Washington, D.C. 20037.

<sup>10</sup>National Fire Protection Association, 1 Batterymarch Park, P.O. Box 9101, Quincy, Massachusetts 02269.

<sup>11</sup>Occupational Safety and Health Administration, U.S. Department of Labor, The *Code of Federal Regulations* is available from the U.S. Government Printing Office, Washington, D.C. 20402.

<sup>12</sup>Schneider Electric—Automation Business, 1 High Street, North Andover, Massachusetts 01845-2699.

<sup>13</sup>American Iron and Steel Institute, 1101 17th Street, N.W., Washington, D.C. 20036-4700.

**3.15 construction agency:** The contractor that installs the machinery train or its associated machinery protection system.

**3.16 contiguous:** Mechanically connected and included in the same housing or rack containing the signal processing and alarm/shutdown/integrity logic functions of the monitor system.

Note: Installation of all monitor system components in the same panel or cabinet is not the same as contiguous.

**3.17 continuous display:** Simultaneous, uninterrupted indication of all status conditions and measured variables in the machinery protection system as required by this standard. It also continuously updates this indication at a rate meeting or exceeding the requirements of this standard.

**3.18 controlled access:** A security feature of a machinery protection system that restricts alteration of a parameter to authorized individuals. Access may be restricted by means such as the use of a key or coded password or other procedures requiring specialized knowledge.

**3.19 dedicated display:** A display which indicates only those parameters from its associated machinery protection system(s) and is not shared with or used to indicate information from other systems such as process controllers, logic controllers, turbine controllers, and so forth.

**3.20 display:** An analog meter movement, cathode ray tube, liquid crystal device, or other means for visually indicating the measured variables and status conditions from the machinery protection system. A display may be further classified as integral or non-integral, dedicated or shared, continuous or non-continuous.

**3.21 dual path:** A configuration of the monitor system such that the same transducer system is used as an input to two separate channels in the monitor system, and different signal processing (such as filtering or integration) is applied to each channel.

Note: An example of this is a single casing vibration accelerometer that is simultaneously processed in the monitor system to both acceleration and velocity for separate filtering, display, and alarming.

**3.22 dual voting logic:** A monitor feature whereby the signals on two channels must both be in violation of their respective setpoints to initiate a change in status (two-out-of-two logic).

**3.23 dynamic range:** The usable range of amplitude of a signal, usually expressed in decibels.

**3.24 electrically isolated accelerometer:** An accelerometer in which all signal connections are electrically insulated from the accelerometer case or base.

**3.25 electronic overspeed detection system:** Consists of speed sensors, power supplies, output relays, signal

processing, and alarm/shutdown/integrity logic. Its function is to continuously measure shaft rotational speed and activate its output relays when an overspeed condition is detected.

**3.26 extension cable:** The interconnection between the proximity probe's integral cable and its associated oscillator-demodulator.

**3.27 field changeable:** Refers to a design feature of a machinery protection system that permits alteration of a function after the system has been installed.

**3.28 filter:** An electrical device that attenuates signals outside the frequency range of interest.

**3.29 g:** A unit of acceleration equal to 9.81 meters per second squared (386.4 in. per second squared).

**3.30 gauss level:** The magnetic field level of a component. It is best measured with a Hall effect probe.

**3.31 inactive (counter) thrust direction:** The direction opposite the active thrust direction.

**3.32 inches per second (ips):** A unit of velocity equal to 25.4 millimeters per second (1 in. per second).

**3.33 integral display:** A display that is contiguous with the other components comprising the monitor system.

**3.34 linear frequency response range:** The portion of the transducer's voltage output versus frequency curve, between lower and upper frequency limits, where the response is linear within a specified tolerance.

**3.35 linear range:** The portion of a transducer's output where the output versus input relationship is linear within a specified tolerance.

**3.36 local:** Refers to a device's location when mounted on or near the equipment or console.

**3.37 machine case:** A driver (for example, electric motor, turbine, or engine) or any one of its driven pieces of equipment (for example, pump, compressor, gearbox, generator, fan). An individual component of a machinery train.

**3.38 machinery protection system:** Consists of the transducer system, signal cables, the monitor system, all necessary housings and mounting fixtures, and documentation (see Figure 1).

**3.39 machinery protection system vendor:** The agency that designs, fabricates, and tests components of the machinery protection system.

**3.40 machinery train:** The driver(s) and all of its associated driven pieces of equipment.

**3.41 machinery vendor:** The agency that designs, fabricates, and tests machines. The machinery vendor may

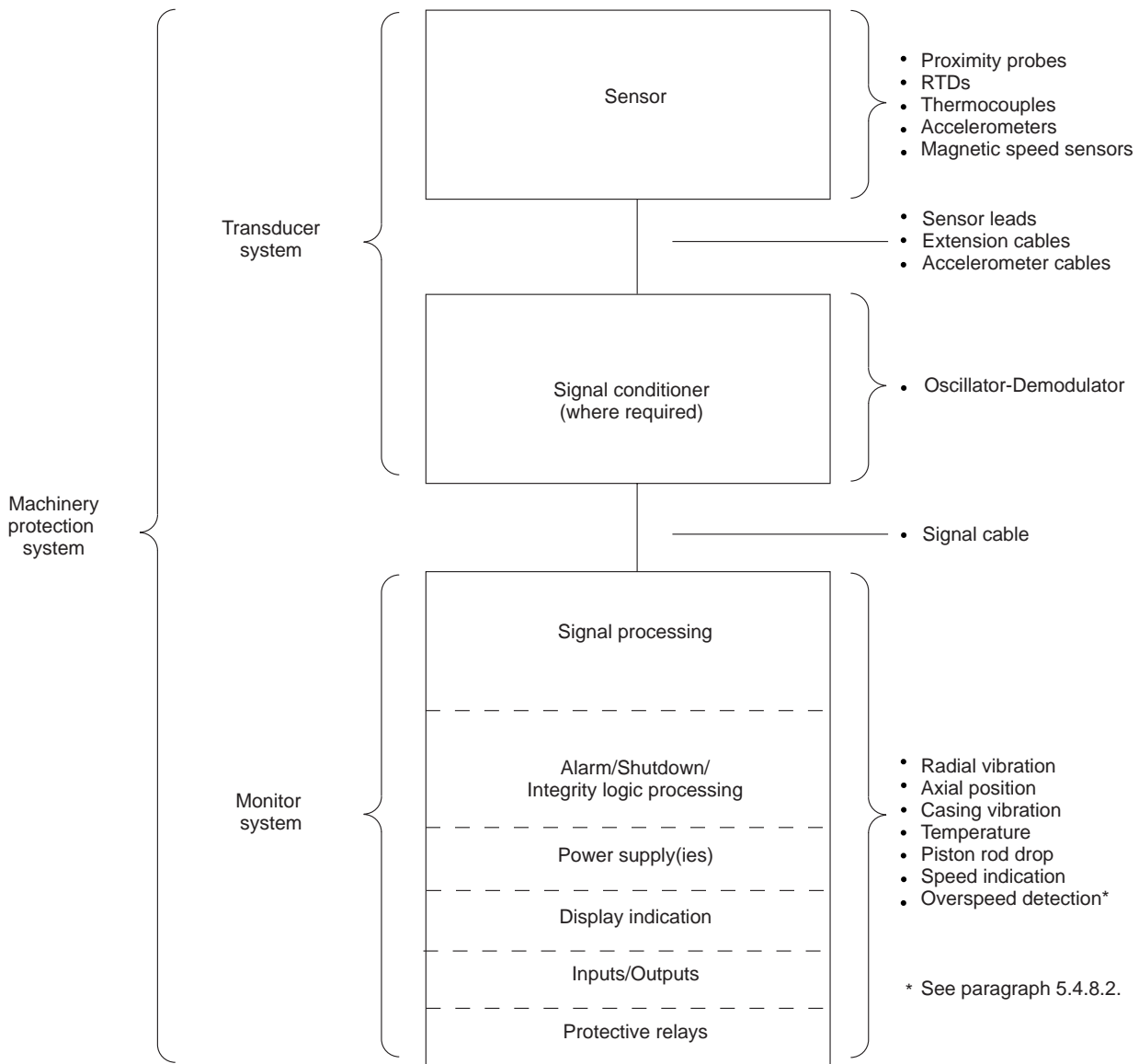

Figure 1—Machinery Protection System

purchase the monitor system or transducer system, or both, and may install the transducers or the sensors on machines.

**3.42 magnetic speed sensor:** Responds to changes in magnetic field reluctance as the gap between the sensor and its observed ferrous target (speed sensing surface) changes. By choosing a proper speed sensing surface, the magnetic speed sensor’s output will be proportional to the rotational speed of the observed surface. Magnetic speed sensors may be either passive (self-powered) or active (require external power).

**3.43 monitor system:** Consists of signal processing, alarm/shutdown/integrity logic processing, power supply(ies), display/indication, inputs/outputs, and protective relays (see Figures 1 and 2).

**3.44 non-integral display:** A display that is not contiguous with the other components comprising the monitor system.

**3.45 oscillator-demodulator:** A signal conditioning device that sends a radio frequency signal to a proximity probe, demodulates the probe output, and provides an output signal suitable for input to the monitor system.

**3.46 overspeed protection system:** An electronic overspeed detection system and all other components necessary to shut down the machine in the event of an overspeed condition. It may include (but is not limited to) items such as trip valves, solenoids, and interposing relays.

**3.47 owner:** The final recipient of the equipment (who will operate the machinery and its associated machinery protection system) and may delegate another agent as the purchaser of the equipment.

**3.48 passive magnetic speed sensor:** A magnetic speed sensor that does not require external power to provide an output.

**3.49 peak-to-peak value (pp):** The difference between positive and negative extreme values of an electronic signal or dynamic motion.

**3.50 phase reference transducer:** A gap-to-voltage device that consists of a proximity probe, an extension cable, and an oscillator-demodulator and is used to sense a once-per-revolution mark.

**3.51 piston rod drop:** A measurement of the position of the piston rod relative to the proximity probe mounting location(s) (typically oriented vertically at the pressure packing box on horizontal cylinders).

Note: Piston rod drop is an indirect measurement of the piston rider band wear on reciprocating machinery (typically addressed by API 618).

**3.52 positive indication:** An active (that is, requires power for annunciation and changes state upon loss of power) display under the annunciated condition. Examples include an LED that is lighted under the annunciated condition or an LCD that is darkened or colored under the annunciated condition.

**3.53 primary probes:** Those proximity probes installed at preferred locations and used as the default inputs to the monitor system.

**3.54 proximity probe:** A noncontacting sensor that consists of a tip, a probe body, an integral coaxial cable, and a connector and is used to translate distance (gap) to voltage.

**3.55 probe area:** The area observed by the proximity probe during measurement.

**3.56 probe gap:** The physical distance between the face of a proximity probe tip and the observed surface. The distance can be expressed in terms of displacement (mils, micrometers) or in terms of voltage (volts DC).

**3.57 purchaser:** The agency that buys the equipment.

**3.58 radial shaft vibration:** The vibratory motion of the machine shaft in a direction perpendicular to the shaft longitudinal axis.

**3.59 remote:** Refers to the location of a device when located away from the equipment or console, typically in a control room.

Power supply(ies)	Vibration channel(s)	Thrust channel(s)	Accelerometer channel(s)	Piston rod drop channel(s)	Speed indicating channel(s)	Temperature channel(s)	Electronic overspeed detection monitor
							Redundant power supplies   3 overspeed sensing channels

Figure 2—Standard Monitor System Nomenclature

**3.60 resistance temperature detector (RTD):** A temperature sensor that changes its resistance to electrical current as its temperature changes.

**3.61 root mean square (rms):** The square root of the mean of the sum of the squares of the sample values.

**3.62 sensor:** A device (such as a proximity probe or an accelerometer) that detects the value of a physical quantity and converts the measurement into a useful input for another device.

**3.63 shaft vibration or position transducer:** A gap-to-voltage device that consists of a proximity probe, an extension cable, and an oscillator-demodulator.

**3.64 shutdown (danger) setpoint:** A preset value of a parameter at which automatic or manual shutdown of the machine is required.

**3.65 signal cable:** The field wiring interconnection between the transducer system and the monitor system.

Note: Signal cable is typically supplied by the construction agency.

**3.66 signal processing:** Transformation of the output signal from the transducer system into the desired parameter(s) for indication and alarming. Signal processing for vibration transducers may include, for example, peak-to-peak, zero-to-peak, or rms amplitude detection; pulse counting; DC bias voltage detection; filtering and integration. The output(s) from the signal processing circuitry are used as inputs to the display/indication and alarm/shutdown/integrity logic circuitry of a monitor system.

**3.67 signal-to-noise ratio:** The ratio of the power of the signal conveying information to the power of the signal not conveying information.

**3.68 spare probes:** Probes installed at alternate locations to take the place of primary probes (without requiring machine disassembly) in the event of primary probe failure.

**3.69 speed sensing surface:** A gear, toothed-wheel, or other surface with uniformly-spaced discontinuities that causes a change in gap between the speed sensing surface and its associated speed sensor(s) as the shaft rotates.

**3.70 speed sensor:** A proximity probe or magnetic speed sensor used to observe a speed sensing surface. It provides an electrical output proportional to the rotational speed of the observed surface.

**3.71 standard option:** A generally available alternative configuration that may be specified in lieu of the default configuration specified herein.

**3.72 tachometer:** A device for indicating shaft rotational speed.

**3.73 temperature sensor:** A thermocouple or resistance temperature detector and its integral sensor lead.

**3.74 thermocouple:** A temperature sensor consisting of two dissimilar metals so joined to produce different voltages when their junction is at different temperatures.

**3.75 transducer system:** A proximity probe, accelerometer, or sensor; an extension or accelerometer cable; and oscillator-demodulator (when required). The transducer system generates a signal that is proportional to the measured variable (see Figure 3).

**3.76 transverse sensitivity:** An accelerometer's response to dynamic loads applied in a direction perpendicular to the principal axis. It is also sometimes called cross-axis sensitivity.

**3.77 unit responsibility:** Refers to the responsibility for coordinating the delivery and technical aspects of the equipment and all auxiliary systems included in the scope of the order. The technical aspects to be considered include, but are not limited to, such factors as the power requirements, speed, rotation, general arrangement, couplings, dynamics, noise, lubrication, sealing system, material test reports, instrumentation (such as the machinery protection system), piping, conformance to specifications and testing of components.

**3.78 velocity transducer:** A piezo-electric accelerometer with integral amplification and signal integration such that its output is proportional to its vibratory velocity.

**3.79 voted channel:** A channel requiring confirmation from one or more additional channels as a precondition for alarm (alert) and shutdown (danger) relay actuation.

## 4 General Design Specifications

### 4.1 COMPONENT TEMPERATURE RANGES

Machinery Protection System components have two temperature ranges, testing range and operating range, over which accuracy shall be measured and in which the system components shall operate, as summarized in Table 1.

Note: The testing range is a range of temperatures in which normal bench testing occurs. It allows verification of the accuracy and operation of transducer and monitor system components without the need for special temperature- or humidity-controlled environments. The operating range represents temperatures over which the transducer and monitor system components are expected to operate in actual service conditions.

### 4.2 HUMIDITY

**4.2.1** For transducer systems, the accuracy requirements of Table 1 shall apply at levels of relative humidity up to 100% condensing, non-submerged, with protection of connectors.



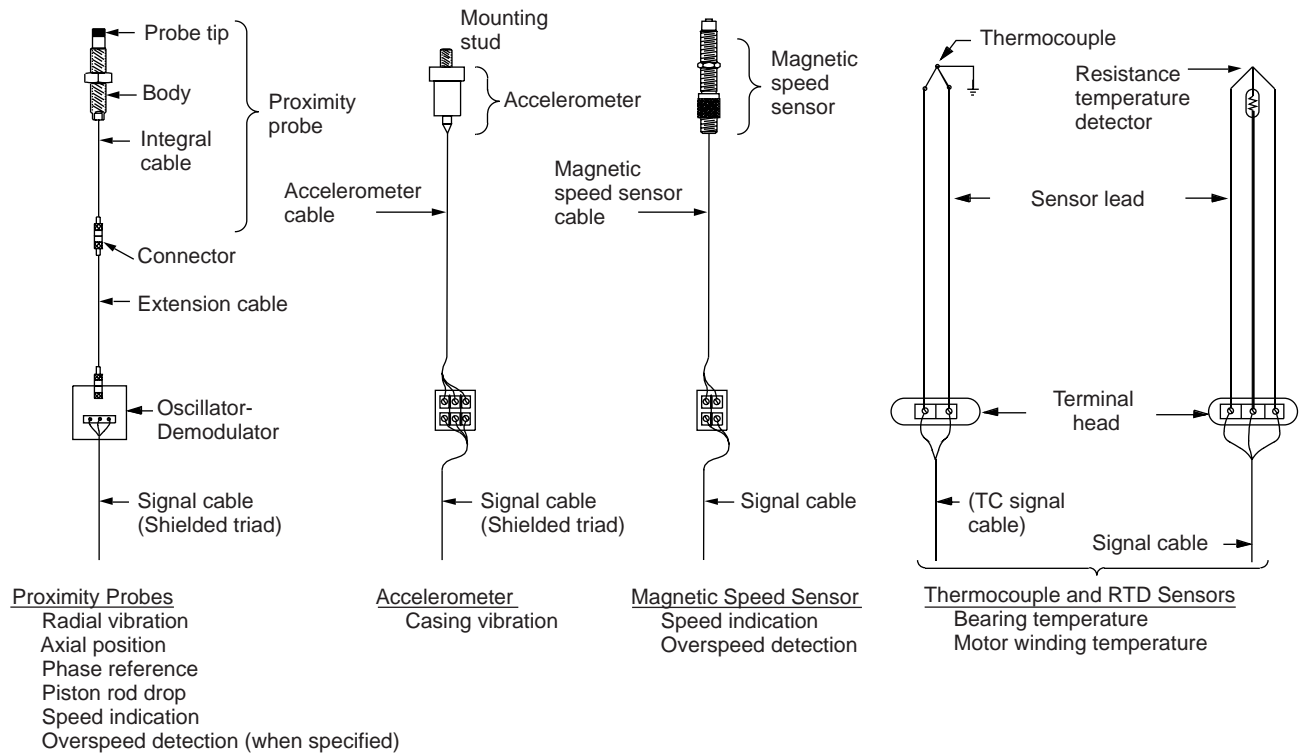

Figure 3—Transducer System Nomenclature

**4.2.2** For monitor system components, the accuracy requirements of Table 1 shall apply at levels of relative humidity up to 95% non-condensing.

**4.3 SHOCK**

Accelerometers shall be capable of surviving a mechanical shock of 5,000 g, peak, without affecting the accuracy requirements specified in Table 1.

**4.4 CHEMICAL RESISTANCE**

**4.4.1** Probes, probe extension cables, and oscillator-demodulators shall be suitable for environments containing hydrogen sulfide and ammonia.

- **4.4.2** It shall be the joint responsibility of the purchaser and machinery protection system vendor to ensure that all of the machinery protection system components are compatible with other specified chemicals.

**4.5 ACCURACY**

**4.5.1** Accuracy of the transducer system and monitor system in the testing and operating temperature ranges shall be as summarized in Table 1.

**4.5.2** If monitor system components or transducer system components will be used in applications exceeding the requirements of Table 1, the machinery protection system vendor shall supply documentation showing how the accuracy is affected or suggest alternative transducer and monitor components suitable for the intended application.

Notes:

1. Some applications may require piston rod drop and axial position measurements with measuring ranges greater than 2 millimeters (80 mils). Special transducer systems, such as those with 3.94 mV per micrometer (100 mV per mil) scale factors, are required for these applications, and are not covered by this standard.

Table 1—Machinery Protection System Accuracy Requirements

Components	Temperature		Accuracy Requirements as a Function of Temperature	
	Testing Range	Operating Range	Within Testing Range	Outside Testing Range but Within Operating Range
Proximity probes	0°C to 45°C (32°F to 110°F)	−35°C to 120°C (−30°F to 250°F)	Incremental Scale Factor <sup>1</sup> : ± 5% of 7.87 mV/μm (200 mV/mil)	Incremental Scale Factor <sup>1</sup> : An additional ±5% of the testing range accuracy
Extension cables	0°C to 45°C (32°F to 110°F)	−35°C to 65°C (−30°F to 150°F)	Deviation from Straight Line <sup>2</sup> : within ±25.4 μm (±1 mil) of the best fit straight line at a slope of 7.87 mV/μm (200 mV/mil)	Deviation from Straight Line <sup>2</sup> : within ±76 μm (±3 mils) of the best fit straight line at a slope of 7.87 mV/μm (200 mV/mil)
Oscillator-demodulators	0°C to 45°C (32°F to 110°F)	−35°C to 65°C (−30°F to 150°F)	Minimum linear range: 2 mm (80 mils)	Minimum linear range: same as for testing range
Accelerometers and accelerometer extension cables <sup>3</sup>	20°C to 30°C (68°F to 86°F)	−55°C to 120°C (−65°F to 250°F)	Principal Axis Sensitivity: 100 mV/g ±5%	Principal Axis Sensitivity: 100 mV/g ±20%
			Amplitude Linearity: 1% from 0.1 g pk to 50 g's pk <sup>4</sup>	
			Frequency Response <sup>5</sup> : ±3 dB from 10 Hz to 10 kHz, referenced to the actual measured principal axis sensitivity <sup>6</sup> .	
Temperature sensors and leads	0°C to 45°C (32°F to 110°F)	−35°C to 175°C (−30°F to 350°F)	±2°C (±4°F) over a measurement range from −20°C to 150°C (0°F to 300°F)	±3.7°C (±7°F) over a measurement range from −20°C to 150°C (0°F to 300°F)
Monitor system components for measuring:				
Radial Vibration, Axial Position, Piston Rod Drop, and Casing Vibration	0°C to 45°C (32°F to 110°F)	−20°C to 65°C (0°F to 150°F)	±1% of full scale range for the channel	Same as for testing range
Temperature			±1°C (±2°F)	Same as for testing range
Speed and Overspeed			±1% of alarm setpoint	Same as for testing range

## Notes:

- The incremental scale factor (ISF) error is the maximum amount the scale factor varies from 7.87 mV per micrometer (200 mV per mil) when measured at specified increments throughout the linear range. Measurements are usually taken at 250 μm (10 mil) increments. ISF error is associated with errors in radial vibration readings.
- The deviation from straight line (DSL) error is the maximum error (in mils) in the probe gap reading at a given voltage compared to a 7.87 mV per micrometer (200 mV per mil) best fit straight line. DSL errors are associated with errors in axial position or probe gap readings.
- During the testing of the accelerometers, the parameter under test is the only parameter that is varied. All other parameters must remain constant.
- Conditions of test: at any one temperature within the Testing Range, at any single frequency that is not specified but is within the specified frequency range of the transducer.
- Frequency Response testing conditions: at any one temperature within the Testing Range, at an excitation amplitude that is not specified but is within the specified amplitude range of the transducer.
- Principal Axis Sensitivity testing conditions: (Testing Range) at any one temperature within the Testing Range, at 100 Hz, at an excitation amplitude that is not specified but is within the specified amplitude range of the transducer. (Operating Range) at any one temperature within the Operating Range, at 100 Hz, at an excitation amplitude that is not specified but is within the specified amplitude range of the transducer.

2. Aeroderivative gas turbines typically require special high-temperature transducer systems that exceed the operating range specified in Table 1, and monitor systems with special filtering based on original equipment manufacturer recommendations. Consult the machinery protection system vendor.

3. Radial vibration or position measurements using proximity probe transducers on shaft diameters as small as 76 mm (3 in.) do not introduce appreciable error compared to measurements made on a flat target area. Shaft diameters smaller than this can be accommodated but generally result in a change in transducer scale factor. Consult the machinery protection system vendor.

4. Proximity probe measurements on shaft diameters smaller than 50 mm (2 in.) may require close spacing of radial vibration or axial position transducers with the potential for their electromagnetic emitted fields to interact with one another (cross-talk) resulting in erroneous readings. Care should be taken to maintain minimum separation of transducer tips, generally at least 40 mm (1.6 in.) for axial position measurements and 74 mm (2.9 in.) for radial vibration measurements.

**4.5.3** The proximity probe transducer system accuracy shall be verified on the actual probe target area or on a target with the same electrical characteristics as those of the actual probe target area (see Figure 4).

**4.5.4** When verifying the accuracy of any individual component of the proximity probe transducer system in the operating range, the components not under test shall be maintained within the testing range.

## 4.6 INTERCHANGEABILITY

**4.6.1** All components covered by this standard shall be physically and electrically interchangeable within the accuracy specified in Table 1. This does not imply that interchangeability of components from different machinery protection system vendors is required, or that oscillator-demodulators calibrated for different shaft materials are electrically interchangeable.

**4.6.2** Unless otherwise specified, probes, cables, and oscillator-demodulators shall be supplied calibrated to the machinery protection system vendor's standard reference target of AISI Standard Type 4140 steel.

Note: Consult the machinery protection system vendor for a precision factory target when verifying the accuracy of the transducer system to this standard. The machinery protection system vendor should be consulted for applications using target materials other than AISI Standard Type 4140 steel as they may require factory re-calibration of the transducer system.

## 4.7 SCOPE OF SUPPLY AND RESPONSIBILITY

**4.7.1** For each train, the purchaser shall specify the agency or agencies responsible for each function of the design, scope of supply, installation, and performance of the monitoring system (see Appendix B).

**4.7.2** The details of systems or components outside the scope of this standard shall be mutually agreed upon by the purchaser and machinery protection system vendor.

## 5 Conventional Hardware

### 5.1 RADIAL SHAFT VIBRATION, AXIAL POSITION, PHASE REFERENCE, SPEED SENSING, AND PISTON ROD DROP TRANSDUCERS

#### 5.1.1 Proximity Probes

**5.1.1.1** A proximity probe consists of a tip, a probe body, an integral coaxial cable, and a connector as specified in 5.1.3, and shall be chemically resistant as specified in 4.4. This assembly is illustrated in Figure 5.

**5.1.1.2** Unless otherwise specified, the standard probe shall have a tip diameter of 7.6 to 8.3 millimeters (0.300 to 0.327 in.), with a reverse mount, integral hex nut probe body approximately 25 millimeters (1 in.) in length and <sup>3</sup>/<sub>8</sub>-24-UNF-2A threads.

Notes:

1. Reverse mount probes are intended for use with probe holders allowing external access to the probe and its integral cable. The use of a reverse mount probe as the standard probe allows a single probe configuration and thread length to be used throughout the entire machine train. The length of the probe holder stem will typically vary from one probe mounting location to the next, but this can be trimmed in the field without the need to employ different probes.

2. Piston rod drop applications do not generally enable reverse mount probes to be used. A standard option forward mount probe should be selected instead.

● **5.1.1.3** When specified, the standard options may consist of one or more of the following forward mount probe configurations (see Figure 6):

a. A tip diameter of 7.6 to 8.3 millimeters (0.300 to 0.327 in.) and <sup>3</sup>/<sub>8</sub>-24-UNF-2A English threads.

b. A tip diameter of 4.8 to 5.3 millimeters (0.190 to 0.208 in.) and <sup>1</sup>/<sub>4</sub>-28-UNF-2A English threads.

c. A tip diameter of 7.6 to 8.3 millimeters (0.300 to 0.327 in.) and M10 x 1 metric threads.

d. A tip diameter of 4.8 to 5.33 millimeters (0.190 to 0.208 in.) and M8 x 1 metric threads.

e. Lengths other than approximately 25 millimeters (1 in.).

f. Flexible stainless steel armoring attached to the probe body and extending to within 100 millimeters (4 in.) of the connector.

**5.1.1.4** The overall physical length of the probe and integral cable assembly shall be approximately 1 meter (39 in.), measured from the probe tip to the end of the connector. The minimum overall physical length shall be 0.8 meters (31 in.); the maximum overall physical length shall be 1.3 meters (51 in.).

Channel Accuracy  
Deviation from best-fit straight line (DSL)  
at a slope of  
7.87 mV per micrometer  
(200 mV per mil)

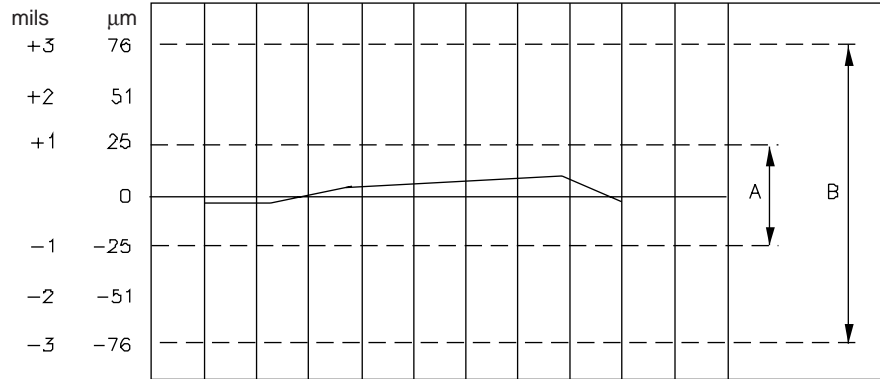

Channel Accuracy  
Incremental scale factor (ISF)  
Referenced to  
7.87 mV per micrometer  
(200 mV per mil)

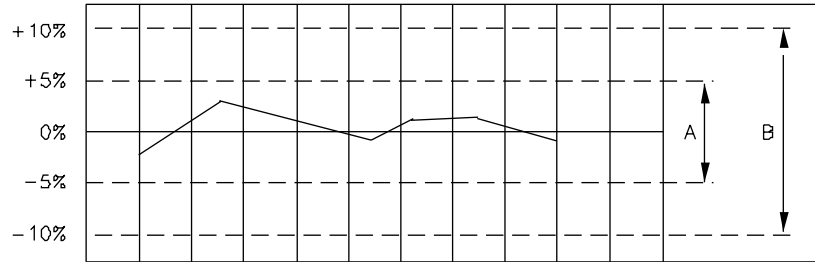

Typical Gap-to-Voltage  
transducing characteristic

Output (volts DC)

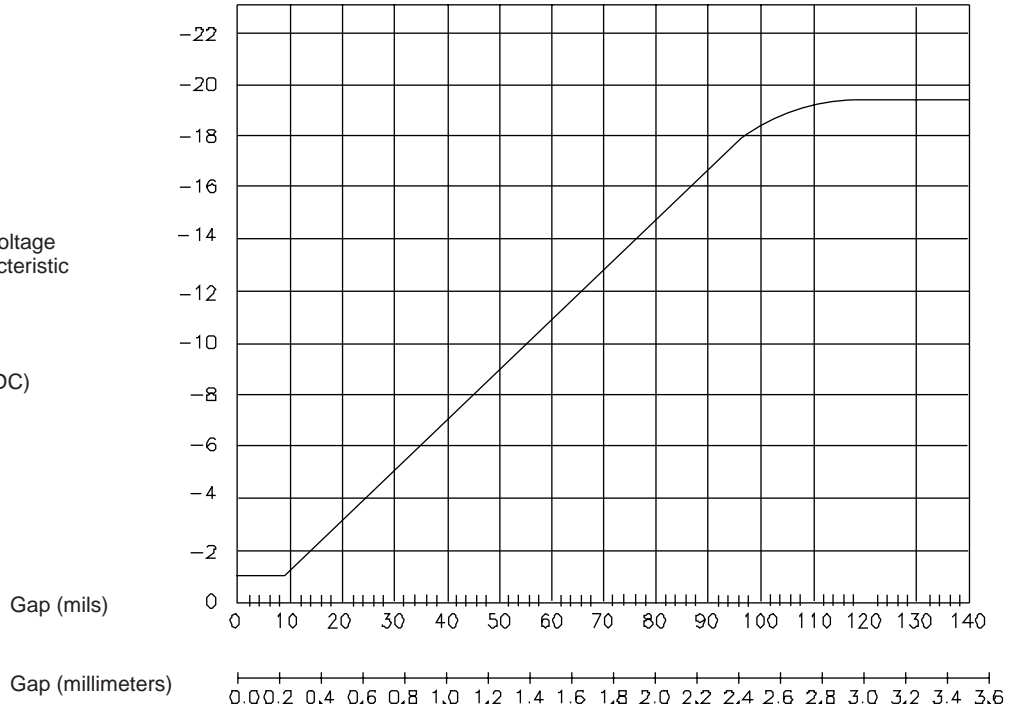

Note:

A – Maximum error during bench test within testing temperature range of 0°C TO 45°C (30°F TO 110°F).  
B – Maximum error over operating temperature range.

Figure 4—Typical Curves Showing Accuracy of Proximity Probe Channels

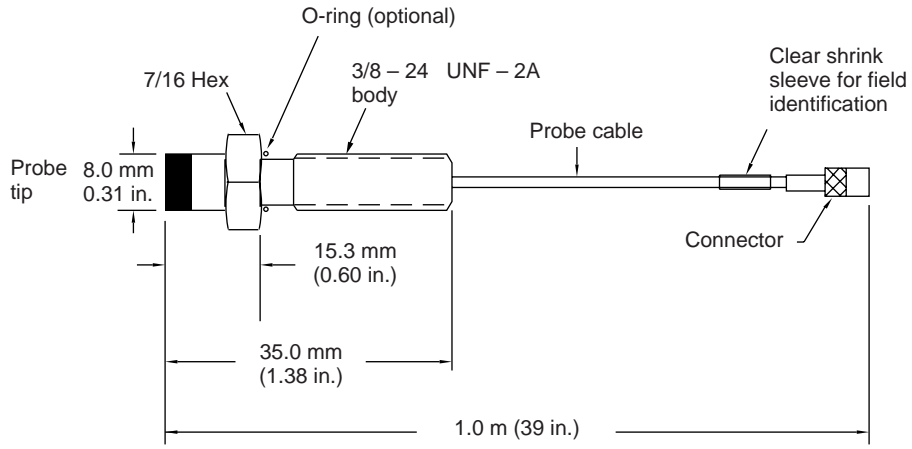

STANDARD PROBE

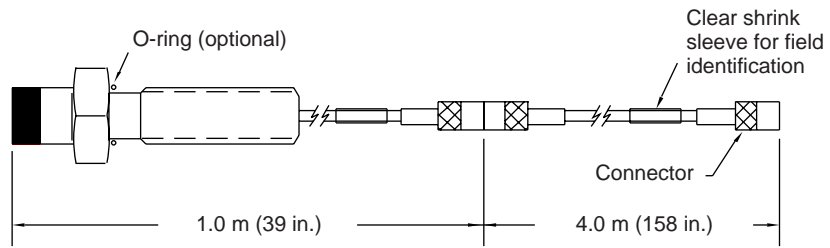

STANDARD PROBE AND EXTENSION CABLE

Figure 5—Standard Probe and Extension Cable

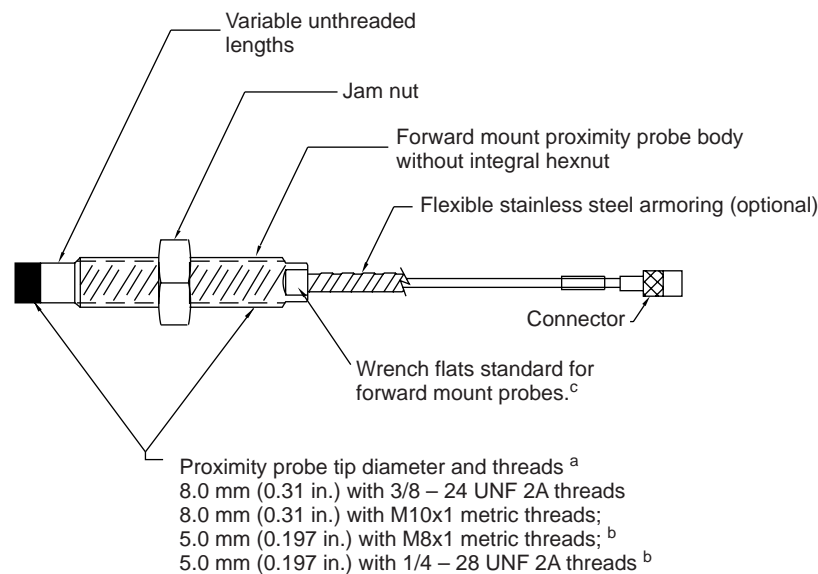

## Notes:

- a. The standard option proximity probe may consist of one or more of the options discussed in 5.1.1.3.
- b. Forward-mount probes are generally only available in case lengths longer than 20.3 millimeters (0.8 in.). A 1/4 – 28 (or M8x1) body more than 51 millimeters (2 in.) in length is undesirable from the standpoint of mechanical strength and availability.
- c. Wrench flats shall be compatible with standard wrench sizes. The dimension of the flats will vary with the diameter chosen for the probe body.

Figure 6—Standard Options for Proximity Probes and Extension Cables

**5.1.1.5** A piece of clear heat-shrink tubing (not to be shrunk at the factory) 40 millimeters (1.5 in.) long shall be installed over the coaxial cable before the connector is installed to assist the owner in tagging.

### 5.1.2 Probe Extension Cables

Probe extension cables shall be coaxial, with connectors as specified in 5.1.3. The nominal physical length shall be 4 meters (158 in.) and shall be a minimum of 3.6 meters (140 in.) (see Figure 5). Shrink tubing shall be provided at each end in accordance with 5.1.1.5.

### 5.1.3 Connectors

The attached connectors shall meet or exceed the mechanical, electrical, and environmental requirements specified in Section 4 and in MIL-C-39012-C and MIL-C-39012/5F. The cable and connector assembly shall be designed to withstand a minimum tensile load of 225 newtons (50 pounds).

### 5.1.4 Oscillator-Demodulators

The standard oscillator-demodulator shall be designed to operate with the standard probe as defined in 5.1.1.2 and the probe extension cable as defined in 5.1.2.

**5.1.4.1** The oscillator-demodulator output shall be 7.87 millivolts per micrometer (200 millivolts per mil) with a standard supply voltage of –24 volts DC. The oscillator-demodulator shall be calibrated for the standard length of the probe assembly and extension cable. The output, common, and power-supply connections shall be heavy-duty, corrosion-resistant terminations suitable for at least 18 American Wire Gage (AWG) wire (1.0 square millimeters cross section). The oscillator-demodulator shall be electrically interchangeable in accordance with 4.6.1 for the same probe tip diameter. The interference or noise of the installed system (including oscillator-demodulator radio-frequency output noise, line-frequency interference, and multiples thereof) on any channel shall not exceed 20 millivolts pp, measured at

the monitor inputs and outputs, regardless of the condition of the probe or the gap. The transducer system manufacturer's recommended tip-to-tip spacing for probe cross-talk must be maintained. The oscillator-demodulator common shall be isolated from ground. Oscillator-demodulators shall be mechanically interchangeable.

Note: The intent of this paragraph is that interchangeability requirements apply only to components supplied by the same vendor.

- **5.1.4.2** When specified, oscillator-demodulators shall be supplied with a DIN rail mounting option.

### 5.1.5 Magnetic Speed Sensors

A magnetic speed sensor consists of the encapsulated sensor (pole piece and magnet), threaded body, and cable.

**5.1.5.1** The standard magnetic speed sensor shall be a passive (that is, self-powered) type with a cylindrical pole piece. The standard body shall have  $\frac{5}{8}$ -18-UNF-2A threads. The maximum diameter of the pole piece shall be 4.75 mm (0.187 in.) (see Figure 7).

- **5.1.5.2** When specified, the standard options may consist of one or more of the following:

- Conical or chisel pole pieces.
- $\frac{3}{4}$ -20 UNEF-2A threads.
- M16 x 1.5 metric threads.
- Explosion-proof design with integral cable and conduit threads at integral cable exit.
- Removable (that is, non-integral) cable and connector.
- An active (that is, externally-powered) magnetic speed sensor.

Note: Active magnetic speed sensors or proximity probes are often used on machines where rotational speeds below 250 rpm must be reliably sensed. Passive magnetic speed sensors do not typically generate a suitable signal amplitude at slow shaft rotational speeds. To sense shaft rotation speeds down to 1 rpm, active magnetic speed sensors or proximity probes are required.

**5.1.5.3** The sensor body and any protective housings for the sensor shall be constructed of non-magnetic stainless steel such as AISI Standard Type 303 or 304.

Note: Magnetic stainless steel, such as AISI Standard Type 416, tends to alter the flux path and reduce the sensor's output voltage. Aluminum housings can decrease the sensor's output voltage and introduce phase shift as speed changes.

**5.1.5.4** The sensor and its associated multi-toothed speed sensing surface must be compatible (refer to Appendix J).

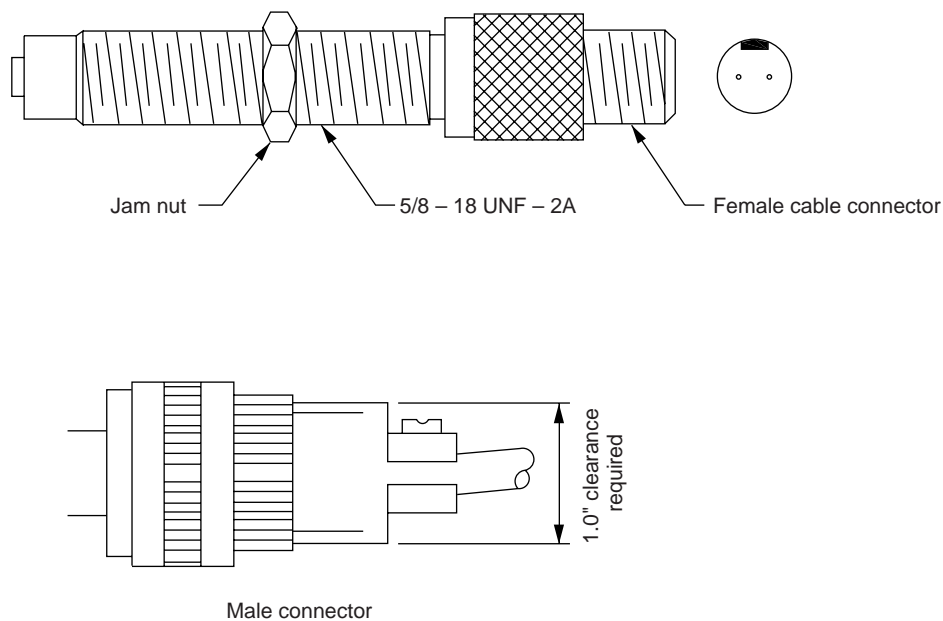

Figure 7—Standard Magnetic Speed Sensor With Removable (Non-Integral) Cable and Connector

## 5.2 ACCELEROMETER-BASED CASING TRANSDUCERS

### 5.2.1 Casing Vibration Transducers

#### 5.2.1.1 Piezoelectric Accelerometers

**5.2.1.1.1** The standard accelerometer system shall be an electrically isolated transducer consisting of a case, a piezoelectric crystal, an integral amplifier, and a connector.

**5.2.1.1.2** The accelerometer case shall be constructed from AISI Standard Type 316 or other equivalent corrosion resistant stainless steel, and shall be electrically isolated from the piezoelectric crystal and all internal circuitry. The case shall be hermetically sealed. The case shall have a maximum outside diameter of 25 millimeters (1 in.). The overall case height shall not exceed 65 millimeters (2.5 in.), not including the connector. The accelerometer case shall be fitted with standard wrench flats.

**5.2.1.1.3** The mounting surface of the accelerometer case shall be finished to a maximum roughness of 0.4 micrometers (16 microinches) Ra (arithmetic average roughness). The center of this mounting surface shall be drilled and tapped (perpendicular to the mounting surface  $\pm 5$  minutes of an arc) with a  $1/4$ -28 UNF-2A threaded hole of 6 millimeters ( $1/4$  in.) minimum depth. The vendor shall supply with each accelerometer a standard mounting option consisting of a double-ended, flanged,  $1/4$ -28 UNF-2A threaded, AISI Standard Type 300 stainless steel mounting stud. The stud shall not prevent the base of the accelerometer from making flush contact with its mounting (see Appendix C). The standard accelerometer shall have a top connector capable of withstanding the operating environment.

- **5.2.1.1.4** When specified, accelerometer standard options may consist of one or more of the following (see Appendix C):

- a. Integral stud for non-flush mounting (see Appendix C).
- b. Mounting stud: U.S. Customary threads other than  $1/4$ -28 UNF.
- c. Mounting stud: metric threads.
- d. Integral accelerometer cable.

**5.2.1.1.5** The accelerometer transverse sensitivity shall not exceed 5% of the principal axis sensitivity over the ranges specified in Table 1.

**5.2.1.1.6** The accelerometer transducer shall have a noise floor no higher than 0.004 g rms over the frequency range specified in Table 1.

#### 5.2.1.2 Accelerometer Cables

**5.2.1.2.1** Accelerometer cables shall be supplied by the machinery protection system vendor. They shall meet the temperature requirements of the accelerometer.

**5.2.1.2.2** Unless otherwise specified, the nominal physical length of the accelerometer cable shall be 5 meters (200 in.).

**5.2.1.2.3** A piece of clear heat-shrink tubing (not to be shrunk at the factory) 40 millimeters (1.5 in.) long shall be installed over the accelerometer cable at each end to assist the owner in tagging.

#### 5.2.1.3 Connectors

The attached connector or connectors shall meet the mechanical, electrical, and environmental requirements of the accelerometer. The body material shall be AISI Standard Type 300 stainless steel. The accelerometer cable and connector assembly shall be designed to withstand a minimum tensile load of 225 newtons (50 pounds).

## 5.3 TEMPERATURE SENSORS

### 5.3.1 Sensors

- **5.3.1.1** The standard temperature sensor shall be a 100-ohm, platinum, three-lead resistance temperature detector with a temperature coefficient of resistance equal to 0.00385 ohm/ohm/ $^{\circ}$ C from 0 $^{\circ}$ C to 100 $^{\circ}$ C (32 $^{\circ}$ F to 212 $^{\circ}$ F). When specified, the standard optional temperature sensor shall be a grounded, Type J iron-copper-nickel (for example, Constantan) thermocouple manufactured in accordance with ANSI MC96.1 (IEC 584-1). Temperature sensors for electrically insulated bearings shall maintain the integrity of the bearing insulation (see 6.2.4.5 Note).
- **5.3.1.2** Sensor leads shall be coated, both individually and overall, with insulation. When specified, flexible stainless steel overbraiding (see note) shall cover the leads and shall extend from within 25 millimeters (1 in.) of the tip to within 100 millimeters (4 in.) of the first connection.

Note: Stainless steel overbraiding may be difficult to seal in some installations.

**5.3.1.3** A 40-millimeter (1.5 in.) piece of clear heat-shrink tubing (not to be shrunk at the factory) shall be installed at the connection end to assist in the tagging of the sensor.

### 5.3.2 Wiring

Wiring from the temperature sensor to the monitor shall be as follows:

- a. For resistance temperature detectors (RTDs), use three-conductor shielded wire in accordance with Appendix D.
- b. For thermocouples, use thermocouple extension wire of the same material as the thermocouple and in accordance with Appendix D.

### 5.3.3 Connectors

The standard installation shall employ a single compression-type, like-metal-to-like-metal connection technique between the sensor and the monitor. Unless otherwise speci-



fied, this connection shall be at a termination block external to the machine. Plug-and-jack, barrier-terminal-strip, or lug connectors shall not be used.

## 5.4 MONITOR SYSTEMS

### 5.4.1 General

**5.4.1.1** The entity with system responsibility for the monitor system shall provide documentation certifying compliance with all provisions of this standard.

**5.4.1.2** Unless otherwise specified, signal processing/ alarm/integrity comparison, display/indication, and all other features and functions specified in Section 5.4 shall be contained in one contiguous enclosure (rack) (refer to Figure 1).

**5.4.1.3** At minimum, each monitor system shall be provided with the following features and functions:

a. A design ensuring that a single circuit failure (power source and monitor system power supply excepted) shall not affect more than two channels of radial shaft vibration, axial position, casing vibration, speed indicating tachometer, or six channels of temperature or rod drop on a single machine case (see note).

Note: The intent of this requirement is to ensure comparable or higher reliability for digital, compared with analog, monitor systems.

- b. When specified, the requirements of Safety Instrumented Systems (SIS) shall apply to some or all of the machinery protection system, and the machinery protection system supplier(s) shall provide the reliability/performance documentation to allow the SIS supplier to determine the safety integrity level for the SIS. SIS requirements are specified by ISA S84.01–1996.
- c. When specified, selected channels (or all channels) of the monitor system shall be available in two additional configurations utilizing redundancy or other means:
  1. A single circuit failure (power source and monitor system power supply excepted) shall only affect the offending channel and shall not affect the state of alarm relays.
  2. A single circuit failure (power source and monitor system power supply included) shall only affect the offending channel and shall not affect the state of alarm relays (see note).

Note: This requirement is mandatory for all electronic overspeed detection system channels (see 5.4.8.4.n and 5.4.1.7.i).

d. All radial shaft vibration, axial position, rod drop, and casing vibration channels, associated outputs, and displays shall have a minimum resolution of 2% of full scale. Temperature channels, associated outputs and displays shall have one (1) degree resolution independent of engineering units. Tachometer and electronic overspeed detection system channels, associated outputs, and displays shall have a resolution of one (1) rpm.

e. Electrical or mechanical adjustments for zeroes, gains, and alarm (alert) and shutdown (danger) setpoints that are field changeable and protected through controlled access. The means for adjustment, including connection(s) for a portable configuration device, shall be accessible from the front of the monitor system. The monitor system alarm and shutdown functions shall be manually or automatically bypassed in accordance with 5.4.1.9 during adjustment.

f. A method of energizing all indicators for test purposes.

g. Printed circuit boards shall have conformal coating to provide protection from moisture, fungus, and corrosion.

Note: Circuit board and backplane connectors may require additional corrosion resistance in extreme environments (that is, gold-plating, gas tight connector design, and so forth). Consult the machinery protection system vendor for availability.

- h. When specified, a monitor system provided with an internal timeclock shall have provisions for remotely setting the time and date through the digital communication port of 5.4.1.4.e.

**5.4.1.4** A monitor system shall include the following signal processing functions and outputs:

a. Isolation to prevent a failure in one transducer from affecting any other channel.

b. A means of indicating internal circuit faults, including transducer system failure, with externally visible circuit fault indication for each individual channel. A no-fault condition shall be positively indicated (for example, lighted). A common circuit fault relay shall be provided for each monitor system. A circuit fault shall not initiate a shutdown or affect the shutdown logic in any way except as noted in paragraphs 5.4.2.4 and 5.4.3.4.

- c. Individual buffered output connections for all system transducers (except temperature) via front-panel bayonet nut connector (BNC) connectors and rear panel connections. When specified, the monitor system may employ connectors other than BNC or locations other than the front panel.

d. Gain adjustment for each radial shaft vibration and axial position channel. Gain adjustment shall be factory calibrated for 7.87 millivolts per micrometer (200 millivolts per mil).

e. A digital output proportional to each measured variable shall be provided at a communications port located at the rear of the monitor system. A short circuit of this output shall not affect the machinery protection system and the output shall follow the measured variable and remain at full scale as long as the measured variable is at or above full scale. Unless otherwise specified, the protocol utilized for this standard digital output shall be Modicon Modbus.

- f. When specified, a 4-20 milliamp DC analog output shall be provided for each measured variable in addition to the digital output of 5.4.1.4.e above.

**5.4.1.5** A monitor system shall include the following alarm and integrity comparison functions:

- a. For each channel, alarm (alert) and shutdown (danger) set-points that are individually adjustable over the entire monitored range.
- b. An alarm (alert) output from each channel to the corresponding alarm (alert) relay. Nonvoting (OR) logic is required.
- c. A shutdown (danger) output from each channel or voted channels to the corresponding shutdown (danger) relay, as discussed in 5.4.2.4, 5.4.3.4, 5.4.4.6, and 5.4.6.4.
- d. With exception of electronic overspeed detection, fixed time delays for shutdown (danger) relay activation that are field changeable (via controlled access) to require from 1 to 3 seconds sustained violation. A delay of 1 second shall be standard.
- e. With exception of electronic overspeed detection (see note), the time required to detect and initiate an alarm (alert) or a shutdown (danger) shall not exceed 100 milliseconds. Relay actuation and the monitor system's annunciation of the condition shall be fixed by the time delay specified in 5.4.1.5.d above.

Note: Electronic overspeed detection system response is specified in Section 5.4.8.4.b

- f. Alarm (alert) indication for each channel or axial position channel pair.
- g. Shutdown (danger) indication for each channel that indicates channel alarm status independent of voting logic. Shutdown (danger) indication shall be positive indication (for example, illuminated when channel violates its shutdown set-point). When specified, shutdown (danger) indication shall conform to operation of the voting logic.
- h. When specified, a tamperproof means for disarming the shutdown (danger) function and a visible indicator (positive indication, for example, lighted when disarmed) shall be provided for each channel. Any disarmed condition shall activate a common relay located in the rack or power supply. This relay shall be in accordance with 5.4.1.8 and may be used for remote annunciation.

Note: This requirement is intended for use to remove a failing or intermittent channel from service.

- i. Front-panel switch and rear-panel connections for remote reset of latching alarm (alert) and shutdown (danger) conditions.
- j. A means to identify the first-out alarm (alert) and the first-out shutdown (danger).

**5.4.1.6** A monitor system shall include the following display/indication functions:

- a. An integral, dedicated display capable of indicating all measured variables, alarm (alert) and shutdown (danger) set-points, and DC gap voltages (for radial shaft vibration, axial

position, piston rod drop, speed indicating tachometer, and electronic overspeed detection channels used with non-contact displacement transducers.) The display shall be updated at a minimum rate of once per second. Unless otherwise specified, the system shall continuously indicate:

1. The higher radial shaft vibration at each bearing.
2. All axial position measurements.
3. The highest temperature for each machine case.
4. The highest casing vibration for each machine case.
5. All standard speed indication and overspeed detection channels.
6. The highest rod drop channel for each machine case.

The display may be an analog, digital, graphic, or other indication specified by the purchaser.

- b. When specified, a non-integral display may be used provided it fulfills all the same measurement and status indication criteria required of the integral version.

When a non-integral display is specified, the signal processing/alarm/integrity components (that is, blind monitor) shall be provided with the following minimum local status indication (positive illumination, for example, lighted in the annunciated condition) as applicable:

1. Power status.
2. Status of the communication link with the non-integral display.
3. System circuit fault.
4. System alarm (alert).
5. System shutdown (danger).
6. System shutdown bypassed.

#### **5.4.1.7 Power Supplies**

- a. The monitor system components shall be capable of meeting the accuracy requirements specified in Table 1 with input voltage to the power supply of 90 to 132 volts AC rms or 180 to 264 volts AC rms, switch selectable, with a line frequency of 50-60 hertz. When specified, the following power supply options may be used:

1. 19 to 32 volts DC.
2. 14 to 70 volts DC.
3. 90 to 140 volts DC.

- b. The monitor system power supply(ies) shall be capable of supplying power to all components of the machinery protection system as defined in 3.38.

Note: Non-integral displays are excepted from this requirement and may be powered by external supplies.

- c. The output voltage to all oscillator-demodulators shall be -24 volts DC with sufficient regulation and ripple suppression to meet the accuracy requirements specified in Table 1.
- d. All power supplies shall be capable of sustaining a short circuit of indefinite duration across their outputs without

damage. Output voltages shall return to normal when an overload or short circuit is removed.

e. The transducer power source shall be designed to prevent a fault condition in one transducer circuit from affecting any other channel.

f. All power supplies shall be immune to an instantaneous transient line input voltage equal to twice the normal rated peak input voltage for a period of 5 microseconds. Such a transient voltage shall not damage the power supplies or affect normal operation of the monitor system.

g. All power supplies shall continue to provide sufficient power to allow normal operation of the monitor system through the loss of AC power for a minimum duration of 50 milliseconds.

h. As a minimum, the input power supply transformer for all instruments shall have separate windings with grounded laminations or shall be shielded to eliminate the possibility of coupling high voltage to the transformer secondary. In case of an insulation fault, the input voltage shall be shorted to ground.

- i. When specified, the monitor system shall be fitted with a redundant power supply capable of meeting all the requirements of 5.4.1.7. This redundant supply shall be capable of accepting the same input voltages or different input voltages as the other power supply (for input voltage options, see 5.4.1.7.a). Each power supply shall be independently capable of supplying power for the entire monitor system, and a failure in one supply and its associated power distribution busses shall not affect the other.

#### 5.4.1.8 System-Output Relays

**5.4.1.8.1** As a minimum, one pair of relays, alarm (alert) and shutdown (danger), shall be provided for each of the following monitored variables:

- a. Axial position.
- b. Radial shaft vibration.
- c. Casing vibration.
- d. Bearing temperature.
- e. Piston Rod drop.

One circuit fault relay shall be provided.

**5.4.1.8.2** As a minimum, one pair of relays, shutdown (danger) and circuit fault, shall be provided for each channel of the electronic overspeed detection system. These relays shall not be shared or voted with any other monitored variables. The shutdown relay on all channels of the electronic overspeed detection system shall be actuated when the voting logic as specified in Section 5.4.8.4 detects an overspeed set-point violation.

- **5.4.1.8.3** Output relays shall be the epoxy sealed electro-mechanical type. When specified, hermetically sealed electro-mechanical type relays shall be provided. The relay control

circuit shall be field changeable to be either normally deenergized or normally energized. Deenergize to alarm and energize to shutdown shall be standard except for overspeed channels. All relays shall be double-pole, double-throw type with electrically isolated contacts. All contacts shall be available for wiring.

**5.4.1.8.4** The relay control circuits for all overspeed channels shall be normally energized.

**5.4.1.8.5** Shutdown (danger), alarm (alert), and circuit-fault relays shall be field changeable to latching (manual reset) or nonlatching (automatic reset). Latching shall be standard.

**5.4.1.8.6** The circuit fault relay shall be normally energized. A failure in the transducer system, monitor system, primary power supply power, or redundant power supply shall deenergize the circuit fault relay.

- **5.4.1.8.7** Contacts shall be rated at a resistive load of 2 amperes at 120 volts AC, or 1 ampere at 240 volts AC, or 2 amperes at 28 volts DC for a minimum of 10,000 operations. When inductive loads are connected, arc suppression shall be supplied at the load. When specified, contacts rated at a resistive load of 5 amperes at 120 volts AC shall be provided.

**5.4.1.8.8** For normally deenergized shutdown (danger) output relays, an interruption of power (line power or DC output power) shall not transfer the shutdown (danger) relay contacts regardless of the mode or duration of the interruption.

**5.4.1.9** A single, tamperproof means of disarming the shutdown function for the entire machinery protection system (except for overspeed channels) shall be provided for each monitor system, along with corresponding status indication (positive indication, for example, lighted when disarmed) and two sets of isolated external annunciator contacts. The system shutdown disarm may be internal or external to the monitor system. Operation or maintenance of the monitor system in the disarmed mode, including power supply replacements, shall not shut down the machine (see note).

Note: This feature is intended to be used during monitor system maintenance only.

- **5.4.1.10** When specified, any one or more of the following shall be available from the digital communications port of 5.4.1.4.e:

- a. Channel status of alarm or no alarm.
- b. Armed/disarmed (maintenance bypass) shutdown status for the monitor system (see 5.4.1.9).
- c. Alarm storage for storing the time, date, and value for a minimum of 64 alarms.
- d. Channel value  $\pm 2\%$  full-scale range resolution.
- e. Measured value as a percent of alarm (alert) and shutdown (danger) values to 1% resolution.
- f. Channel status; armed/disarmed (see 5.4.1.5.h).

- g. Transducer OK Limits.
- h. Hardware and software diagnostics.
- i. Communication link status.
- j. Alarm setpoints.
- k. Gap voltage, when applicable.
- l. Current system time, time stamp and date of event for all transmitted data.
- m. System entry log to include date, time, individual access code, and record of changes.
- n. Setpoint multiplier invoked (see 5.4.2.5 and 5.4.5.4).

#### ● 5.4.1.11 Location of Monitor Systems

The purchaser shall specify whether monitor systems are to be located indoors or outdoors (see note).

Note: Outdoor installations must be designed and located to avoid adverse vibrational and environmental effects. Area classification, orientation, prevailing lighting conditions, display brightness, and legibility must all be considered.

#### 5.4.2 Radial Shaft Vibration Monitoring

- 5.4.2.1 The full-scale range for monitoring radial shaft vibration shall be from 0 to 125 micrometers (0 to 5 mils) true peak-to-peak displacement. When specified, the standard optional full-scale range shall be from 0 to 250 micrometers (0 to 10 mils) true peak-to-peak displacement.

5.4.2.2 The radial shaft vibration circuit fault system shall be set to actuate at 125 micrometers (5 mils) less than the upper limit and 125 micrometers (5 mils) more than the lower limit of the transducer's linear range. The minimum allowable setting for the lower limit shall be 250 micrometers (10 mils) absolute gap.

5.4.2.3 Radial shaft vibration shall be monitored in paired channels from the two transducers mounted at each bearing.

5.4.2.4 The radial shaft vibration shutdown system shall be field changeable so that one (single logic) or both (dual voting logic – see note) transducer signals must reach or violate the setpoint to activate a shutdown (danger) relay. Dual voting (two-out-of-two) logic shall be standard.

Note: In a dual voting logic system, although each channel may have reached or violated its respective shutdown (danger) setpoints at different times, both channels must be jointly and continuously at or above the shutdown (danger) setpoint for the time delay specified in 5.4.1.5.d before the shutdown (danger) relay activates. In the event of failure of a single radial shaft vibration channel transducer or circuit, only the circuit-fault alarm will activate [that is, the shutdown (danger) relay will not activate].

- 5.4.2.5 When specified, a controlled-access function shall be provided such that actuation by an external contact closure causes the alarm (alert) and shutdown (danger) setpoints to be increased by an integer multiple, either two (2) or three (3). A multiplier of three (3) shall be standard. Positive indication

(for example, lighted), shall be provided on the monitor system when the multiplier is invoked.

Note: The use of setpoint multiplication is strongly discouraged unless it is clearly required. Refer to Appendix I for guidance on when setpoint multiplication may be required.

5.4.2.6 Altering a vibration measurement to arithmetically subtract (suppress) mechanical or electrical runout or electrical noise shall not be allowed.

#### 5.4.3 Axial Position Monitoring

5.4.3.1 The full scale range for axial position monitoring shall be from –1.0 to +1.0 millimeters (–40 to +40 mils) axial movement.

5.4.3.2 The axial position circuit-fault system shall be set to actuate at the end of the transducer's linear range but not closer than 250 micrometers (10 mils) of absolute probe gap.

5.4.3.3 Axial position shall be monitored in paired channels. The monitoring system shall be capable of displaying the deviation from zero for both channels. The two channels may share common alarm (alert) and shutdown (danger) setpoints, but shall have separate zeroing and gain adjustments.

5.4.3.4 The axial position shutdown system shall be field changeable so that one (single logic) or both (dual voting logic, see note following) transducer signals must reach or violate the shutdown (danger) setpoint to actuate the shutdown (danger) relay. Dual voting (two out of two) logic shall be standard.

Note: In an axial position dual voting logic system, although each channel may have reached or violated its respective preset shutdown (danger) setpoints at different times, both channels must jointly and continuously be at or above the shutdown (danger) setpoints for the time delay specified in 5.4.1.5.d before the shutdown (danger) relay activates. In the event of the failure of a single transducer or circuit, only the circuit-fault alarm and the alarm (alert) will activate [that is, the shutdown (danger) relay will not activate]. The shutdown (danger) relay will activate when any of the following conditions occur:

- a. Both axial position transducers or circuits fail.
- b. Either channel has failed, and the other channel has violated the shutdown (danger) setpoint.
- c. Both channels jointly violate the shutdown (danger) setpoint.

5.4.3.5 Each axial position monitoring channel shall be field changeable so that the display will indicate either upscale or downscale with increasing probe gap. Indicating upscale with increasing probe gap shall be standard.

#### 5.4.4 Piston Rod Drop Monitoring

- 5.4.4.1 When specified, piston rod drop monitoring shall be provided.

Note: This measurement is made to prevent the piston from contacting the cylinder liner by monitoring the rider band wear (see Figure 8).

**5.4.4.2** Unless otherwise specified, the piston rod drop monitor system shall include a once-per-crank-revolution signal using a phase reference transducer of Section 6.1.4 for timing the measurement location on the piston rod and for diagnostic purposes (see Figure 9).

- **5.4.4.3** The piston rod drop monitor system shall be supplied with one channel per piston rod. When specified, two channels per piston rod for X-Y measurements shall be provided (see also 6.1.3.6).

**5.4.4.4** The piston rod drop monitor display range shall be from 9.99 millimeters (400 mils) rod rise to 9.99 millimeters

(400 mils) rod drop with a minimum of 10 micrometers (SI units) or 1 mil (U.S. Customary units) resolution.

Note: See Figure 8 to determine rod drop limiting clearance. The limiting clearance may be the clearance between the rod and the pressure packing case.

**5.4.4.5** The piston rod drop monitor circuit-fault system shall be set to actuate at the end of the transducer's linear range but not closer than 1 millimeter (40 mils) of absolute proximity probe gap.

**5.4.4.6** Unless otherwise specified, the piston rod drop monitor's shutdown (danger) function shall activate if any individual sensor reaches or violates the shutdown (danger) setpoint for any channel.

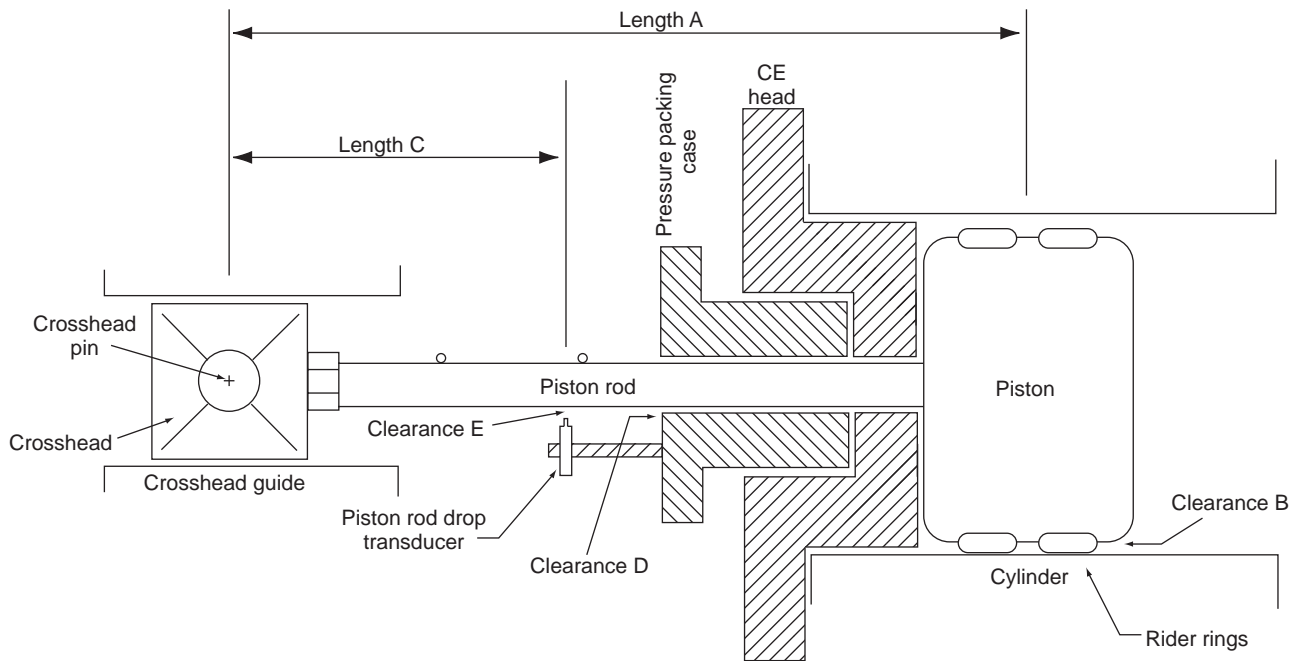

- Length A (Crosshead pin to piston center) \_\_\_\_\_
- Clearance B (Clearance between piston and cylinder, bottom) \_\_\_\_\_
- Length C (Crosshead pin to piston rod drop transducer) \_\_\_\_\_
- Clearance D (Packing case to Piston Rod, bottom) \_\_\_\_\_
- Clearance E (Piston rod to transducer tip, rod drop) \_\_\_\_\_

**Calculation 1:** Piston rod drop limiting clearance.

This calculation is required to determine whether the component limiting the running clearance is the pressure packing case clearance or the piston-to-cylinder clearance.

- a) If  $A \times D/C < B$ , then the pressure packing case clearance is limiting; otherwise the piston-to-cylinder clearance is limiting.
- b) If the piston-to-cylinder clearance is limiting, the maximum rod drop at the transducer is  $C \times B/A$ .

**Calculation 2:** Convert piston rod drop to piston drop.

A change in clearance E represents a loss of piston-to-cylinder clearance as follows:  
 Piston drop =  $\Delta E \times A/C$ .

Figure 8—Piston Rod Drop Calculations

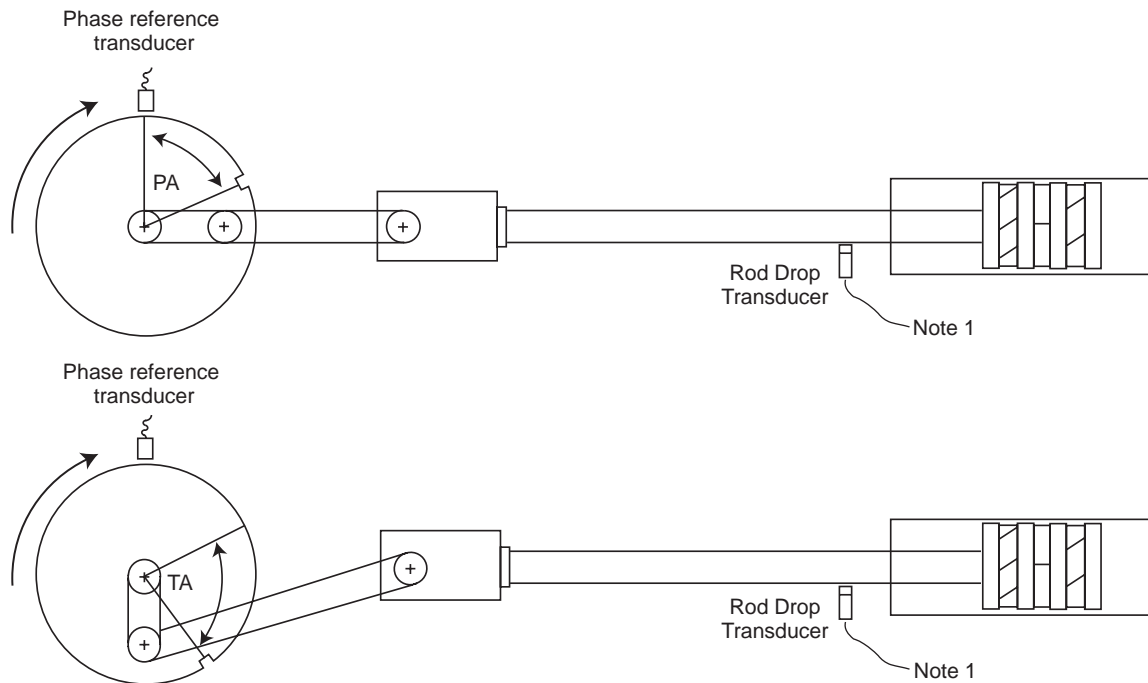

Piston Angle (PA)= The number of degrees, in the direction of rotation, between phase reference mark and the phase reference transducer when the piston is at top dead center (TDC).

Trigger Angle (TA)= The number of degrees, in the direction of rotation, between TDC and where in the stroke you want the reading to be taken. (Should not be too close to TDC or bottom dead center (BDC)).

Note 1: Rod drop transducer mounting should consider the direction the rod will move (toward or away) from the probe as the rider bands wear.

Figure 9—Piston Rod Drop Measurement Using Phase Reference Transducer For Triggered Mode

**5.4.4.7** The piston rod drop monitor shall be able to calculate piston rise or piston drop based on the position of the piston rod, the position of the proximity probe, and measurements of different machinery components.

**5.4.4.8** The piston rod drop monitor system shall be capable of being reset to its initial rider band wear setting after reaching operating temperature to compensate for thermal growth of the piston.

Note: The initial running position of the piston rod will change due to thermal growth of the piston and pressures encountered when in operation.

**5.4.4.9** The monitor scale factor shall be field changeable to either 7.87 mV per micrometer (200 mV per mil) or 3.94 mV per micrometer (100 mV per mil) to match the output of the transducer system employed. Unless otherwise specified, 7.87 mV per micrometer (200 mV per mil) shall be standard.

**5.4.4.10** The piston rod drop monitor system scale factor shall be adjustable within  $\pm 50\%$  of the nominal sensitivity value to accommodate different materials, coatings, and coating thicknesses on the piston rod.

Discussion:

Piston rods or plungers may be manufactured from (or coated with) a variety of materials, and are often coated with chrome or tungsten carbide. These factors can affect transducer sensitivity requiring field calibration of the piston rod drop monitor system. In order to maintain accuracy in these cases, an adjustable scale factor is necessary. The machinery protection system vendor should be advised of materials and composition (including any coating) of the rod to be monitored to provide proper transducer calibration.

**5.4.4.11** The piston rod drop monitor system shall be capable of displaying rider band wear in two separate modes.

- a. Display rider band wear based on the instantaneous gap voltage at a specific and consistent point on each piston stroke (triggered mode).
- b. Display rider band wear based on the average gap voltage throughout the stroke (average mode).

Discussion:

The piston rod drop transducer system measures all piston rod movements. These movements are caused by not only rider band wear, but may also include one or more of the following:

- a. Rod mechanical runout due to crosshead-to-cylinder misalignment in the measurement plane.
- b. Rod deflection.
- c. Forces imposed by load and process condition changes.

These conditions occur in all reciprocating machines to varying extents and can potentially lead to erroneous conclusions regarding rider band wear when displayed in the average mode. In order to minimize these effects and obtain the most reliable indication of rider band wear, it is necessary to use the triggered mode. To use the triggered mode properly, find a point on the stroke where the gap voltage changes due to all influences other than rider band wear are minimized. This must be done through field testing during commissioning of the piston rod drop monitor.

The most effective way of interpreting piston rod drop measurements is through the application of long- and short-term trending. This trending allows users to reliably determine rider band wear.

**5.4.4.12** The piston rod drop monitor shall be capable of indicating piston rod runout when the crankshaft is slowly rotated (2 rpm or below).

Note: The triggered mode should not be used for this measurement.

## 5.4.5 Casing Vibration Monitoring

**5.4.5.1** Requirements in this section apply to monitoring casing vibration utilizing acceleration transducers on machines such as gears, pumps, fans, and motors equipped with rolling element bearings. Unless otherwise specified, machines with fluid film bearings that are designated for monitoring shall be equipped with shaft displacement monitoring in accordance with the system arrangements in Appendix H.

Notes:

1. When casing vibration is used for machine protection, velocity measurements are recommended (see Appendix E). Acceleration measurements should be used to indicate condition and not for machine protection.
2. While unfiltered overall vibration is necessary for test stand acceptance measurements (such as outlined in API 610), it is generally not recommended for machinery protection or continuous monitoring applications. Experience has shown that the default filtered

velocity range in 5.4.5.5.b is generally desirable for eliminating spurious noise sources and potential false alarms.

**5.4.5.2** The monitored frequency range of each casing vibration channel shall be fixed with two field-changeable filters, high and low pass, or equivalent. Filters, or equivalent, used to set the frequency range, shall have the following characteristics:

- a. Unity gain and no loss in the passband greater than 0.5 decibel, referenced to the input signal level.
- b. A minimum roll-off rate of 24 decibels per octave at the high and low cutoff frequency (−3 decibels).
- c. Filtering shall be accomplished prior to integration.
- d. Unless otherwise specified, casing velocity shall be monitored within a filter passband from 10 hertz to 1,000 hertz.

**5.4.5.3** The casing vibration circuit fault system shall activate whenever an open circuit or short circuit exists between the monitor system and accelerometer. The circuit fault system shall be latching and shall inhibit the operation of the affected channel until the fault is cleared and the channel reset.

- **5.4.5.4** When specified, a controlled-access function shall be provided such that actuation by an external contact closure causes the alarm (alert) and shutdown (danger) setpoints to be increased by an integer multiple, either two (2) or three (3). A multiplier of three (3) shall be standard. Positive indication (for example, lighted), shall be provided on the monitoring system when the multiplier is invoked.

Note: The use of setpoint multiplication is strongly discouraged unless it is clearly required. Refer to Appendix I for guidance on when setpoint multiplication may be required.

**5.4.5.5** Unless otherwise specified, the following sets forth requirements for monitoring casing vibration on gears, pumps, fans, and motors equipped with rolling element bearings.

- a. Gear casing vibration shall be monitored in acceleration and velocity modes from a single accelerometer.

Acceleration shall be monitored in a frequency range between 1,000 hertz and 10 kilohertz from 0 to 500 meters per second squared true peak (0 to 50 g's true peak).

Note: As an alternate, an acceleration filter bandwidth centered on the gear mesh frequency with low and high pass filter settings from three to six times the rotational frequency of the high speed pinion may be considered.

Velocity shall be monitored in a frequency range between 10 hertz and 1,000 hertz; amplitude from 0 to 20 millimeters per second rms (0 to 1.0 ips rms).

- b. Pumps, fans, and motors with rolling element bearings (see notes following Section 5.4.5.1):

Velocity shall be monitored in a frequency range from 10 hertz to 1,000 hertz: amplitude from 0 to 25 millimeters per second rms (0 to 1 ips rms).

When specified, acceleration shall be monitored from the same transducer in a frequency range from 10 hertz to 5 kilohertz; amplitude from 0 to 100 meters per second squared true peak (0 to 10 g's true peak).

Equipment operating at shaft speeds from 750 rpm down to 300 rpm should be monitored in a frequency range from 5 hertz to 1,000 hertz.

- **5.4.5.6** When specified, a casing vibration monitor system shall include one or more of the following options:
  - a. Monitor and display of single channel acceleration or velocity.
  - b. Monitor and display two channels in either acceleration or velocity.
  - c. Monitor and display alternate filter or frequency ranges.
  - d. Monitor and display unfiltered overall vibration (see note 2 following 5.4.5.1).
  - e. Monitor and display in true root mean square (rms).
  - f. Monitor and display in true peak.
  - g. Alternate full-scale ranges.
  - h. Dual voting logic.

#### 5.4.6 Temperature Monitoring

- **5.4.6.1** The full-scale range for temperature monitoring shall be available in either SI (0°C to 150°C) or U.S. Customary Units (0°F to 300°F) as specified, with a minimum resolution of one (1) degree independent of engineering units. When thermocouples are used, temperature monitor systems shall be designed to be suitable for grounded thermocouples.
- 5.4.6.2** A fault in the temperature monitor or its associated transducers shall initiate the circuit-fault status alarm. Down-scale failure (that is, a failure in the zero direction) shall be standard.
- 5.4.6.3** Temperature monitoring shall include the capability of displaying all monitored values. Unless otherwise specified, the display shall include automatic capability to display the highest temperature.
- 5.4.6.4** The temperature monitoring shutdown (danger) function shall be field changeable to allow either of the following two possible configurations:
  - a. Any individual sensor must reach or violate the shutdown (danger) setpoint.
  - b. Dual voting logic between predetermined pairs of sensors must reach or violate the shutdown (danger) setpoint.

Dual voting logic shall be standard when two sensors are installed in the load zone of the bearing. Single violations (OR logic) shall be standard for all other sensor configurations.

#### 5.4.7 Speed Indicating Tachometer

- **5.4.7.1** When specified, a speed indicating tachometer shall be provided. It shall have the ability to record and store the highest measured rotational speed (rpm), known as peak speed.
- **5.4.7.2** When specified, controlled access reset capability for the peak speed function shall be available both locally and remotely. A speed indicating tachometer shall not be used for overspeed protection.

**5.4.7.3** The system shall accept transducer inputs from either standard probes or magnetic speed sensors.

#### 5.4.8 Electronic Overspeed Detection

- **5.4.8.1** When specified, an electronic overspeed detection system shall be supplied.

Note: The electronic overspeed detection system is only one component in a complete overspeed protection system. This standard does not address these other components such as solenoids, interposing relays, trip valves, and so forth. Refer to the machinery standard for the machine in question (such as API 612) for details pertaining to these other components of the overspeed protection system.

**5.4.8.2** The electronic overspeed detection system shall be dedicated to the overspeed detection function only. It shall be separate from and independent of all other control or protective systems such that its ability to detect an overspeed event and activate its output relays does not depend in any way upon the correct operation of these other systems and does not depend on these other systems to trip the machine.

Note: The intent of this paragraph is to prevent the electronic overspeed detection system hardware from being combined with hardware from other systems or from using other interposing control or automation systems between the electronic overspeed detection system and the other components of the overspeed protection system (such as interposing relays or solenoids).

This requirement for complete segregation of the electronic overspeed detection system from other systems includes not only the hardware for process control and machine control systems, but also the hardware used for other machinery protection functions described in this standard such as radial vibration, axial position, temperature, and so forth.

**5.4.8.3** When digital or analog communication interfaces are provided, they shall not form part of the overspeed protection system and shall not affect its operation in any way.

Note: The intent of this paragraph is to allow status and other data from the electronic overspeed detection system to be shared with process control, machine control, emergency shutdown, or other control and automation systems via digital or other interfaces.



**5.4.8.4** The electronic overspeed detection system shall satisfy the following requirements:

- a. The system shall be based on three independent measuring circuits and two-out-of-three voting logic.
- b. Unless otherwise specified, the system shall sense an overspeed event and change the state of its output relays within 40 milliseconds when provided with a minimum input signal frequency of 300 Hz. Response time must consider complete system dynamics (see note) as outlined in ASME PTC 20.2-1965 Section 7.

Note: 40 millisecond response time may not be adequate in all cases to keep the rotor speed from exceeding the maximum allowed for the machine. Give consideration to the following:

1. The electronic overspeed detection system is only one part of the total overspeed protection system. Total system response time is affected by, but not limited to, the rotor acceleration rate, the electronic overspeed detection system, the trip valve(s), the electro-hydraulic solenoid valves, the entrained potential energy downstream of the trip valve(s) and in the machine, and (where applicable) the extraction check valve(s).
  2. To achieve proper electronic overspeed detection system response time, a minimum number of events per unit time is required. This is dependent on the method of speed sensing employed and could, for example, be affected by the number of teeth on the speed sensing surface, the tooth profile, and the shaft rotational speed (refer to Appendix J).
  3. The use of intrinsic safety barriers to meet hazardous area classification requirements may introduce signal delays that preclude the system from meeting acceptable response time criteria. Care should be taken to consider these effects when designing the electronic overspeed detection system and choosing components. Alternative methods should be considered as required to meet the area classification requirements.
- c. An overspeed condition sensed by any one circuit shall initiate an alarm.
  - d. An overspeed condition sensed by two out of three circuits shall initiate a shutdown.
  - e. Failure of a speed sensor, power supply, or logic device in any circuit shall initiate an alarm only.
  - f. Failure of a speed sensor, power supply, or logic device in two out of three circuits shall initiate a shutdown.
  - g. Items c, d, e, and f shall require manual reset.
  - h. All settings incorporated in the overspeed circuits shall be field changeable and shall be protected through controlled access.
  - i. Each overspeed circuit shall accept inputs from a frequency generator for verifying the trip speed setting.
  - j. Each overspeed circuit shall provide an output for speed readout.
  - k. The speed sensors used as inputs to the electronic overspeed detection system shall not be shared with any other system.

- l. A peak hold feature with controlled access reset shall be provided to indicate the maximum speed reached since last reset.

Note: Depending on system design, it may be necessary to reset the peak hold feature after testing to ensure that maximum rotor speed reached during an actual overspeed event is captured.

- m. Activation of online testing functions shall only be permitted through controlled access.
- n. The system shall be provided with fully redundant power supplies in accordance with 5.4.1.7.i.

Note: These power supplies should be energized by the purchaser's independent and uninterruptible instrument branch power circuits.

- o. The electronic overspeed detection system shall accept speed sensor inputs from either magnetic speed sensors or proximity probes (see 6.1.6). Unless otherwise specified, the inputs shall be configured to accept passive magnetic speed sensors.

## 5.5 WIRING AND CONDUITS

### 5.5.1 General

Installation shall be in accordance with the following:

- a. Wiring and conduits shall comply with the electrical practices specified in NFPA 70 (see Figures 10, 11, 12, C-1, and C-2).
- b. All conduit, signal and power cable, and monitor system components shall be located in well-ventilated areas away from hot spots such as piping, machinery components, and vessels.
- c. Machinery protection system components shall not be covered by insulation or obstructed by items such as machinery covers, conduits, and piping.
- d. All conduits, armored cable, and similar components shall be located to permit disassembly and repair of equipment without causing damage to the electrical installation.
- e. Signal and power wiring shall be segregated according to good instrument installation practices (see 5.5.2.4).
- f. Signal wiring shall not be run in conduits or trays containing circuits of more than 30 volts of either alternating or direct current.
- g. Signal wiring shall be shielded, twisted pair, or shielded triad to minimize susceptibility to electromagnetic or radio frequency interference.

### 5.5.2 Conduit Runs To Panels

#### 5.5.2.1 Conduits shall be:

- a. Weatherproof and of suitable size to meet NFPA 70 requirements for the size and number of signal cables to be installed.
- b. Supplied with a drain installed at each conduit low point.

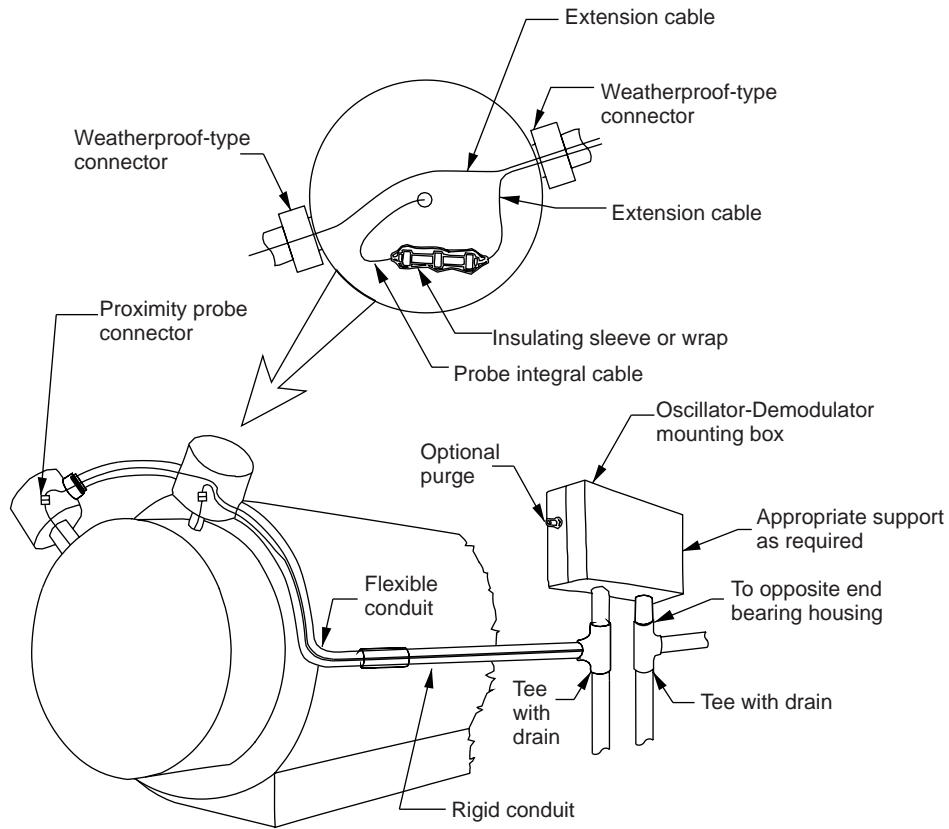

Note: Proximity probe extension cable connectors shall be insulated from the ground.

Figure 10—Typical Standard Conduit Arrangement

**5.5.2.2** Signal cable installed in underground conduit shall be suitable for continuous operation in a submerged environment.

Note: Underground conduit will accumulate moisture over long periods of time regardless of the sealing methods employed.

**5.5.2.3** Signal cables shall:

- a. Be supplied in accordance with the provisions of Appendix D.
- b. Not exceed a physical length of 150 meters (500 feet). The use of longer cable runs must be reviewed and approved in writing by the machinery protection system vendor.
- c. Use continuous runs only. The use of noncontinuous runs must be approved by the owner and, if employed, the shield shall be carried across any junction.

**5.5.2.4** The minimum separation between installed signal and power cables shall be as specified in Table 2 (see note).

Note: More detailed information on signal transmission systems is available in API Recommended Practice 552.

Table 2—Minimum Separation Between Installed Signal and Power Cables

Voltage AC	Minimum Separation	
	Millimeters	Inches
120	300	12
240	450	18
480	600	24

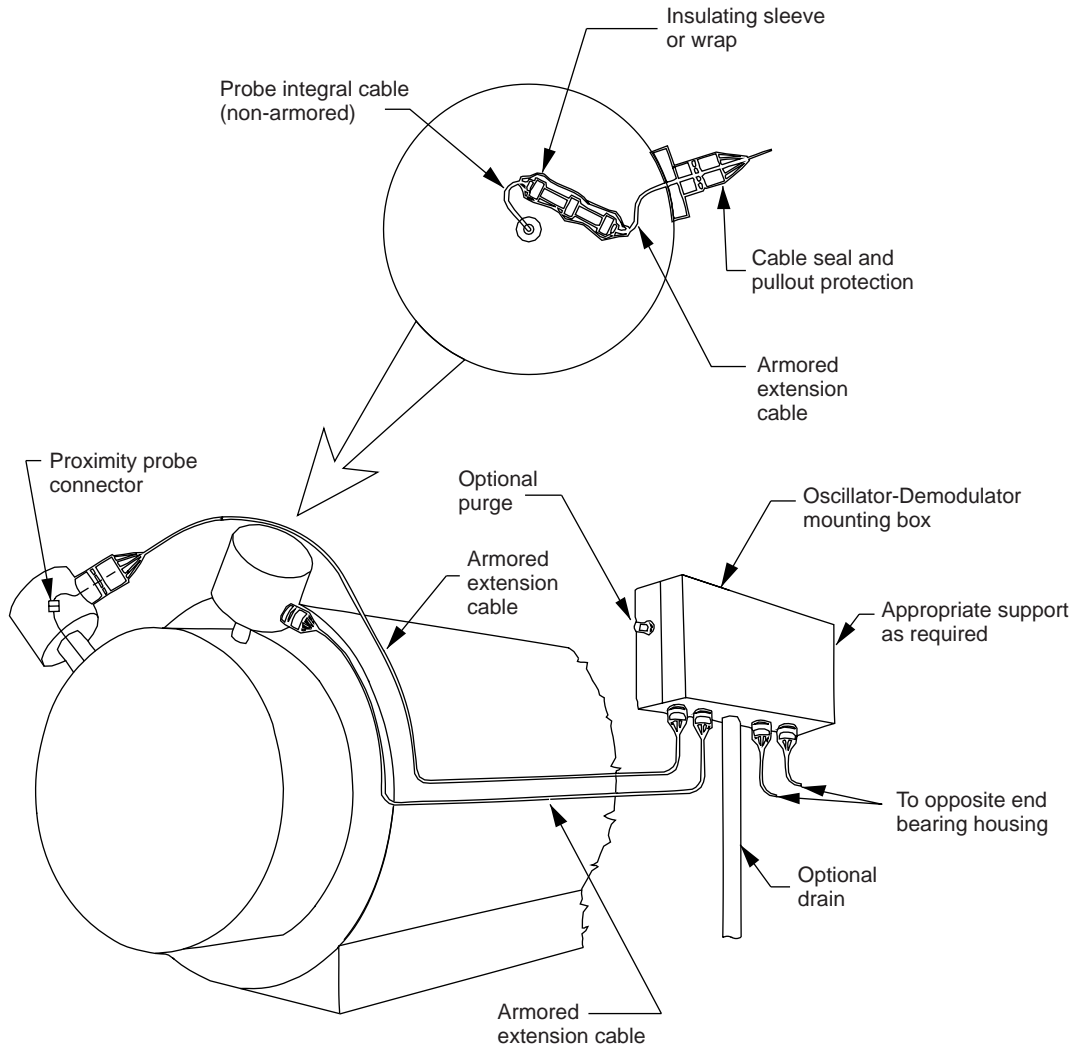

Figure 11—Typical Standard Armored Cable Arrangement

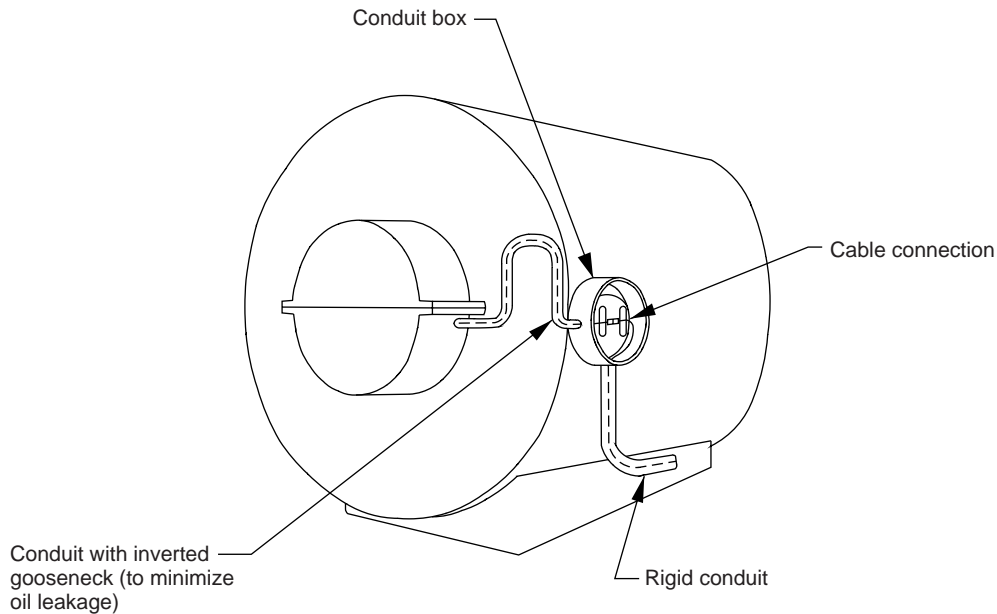

Figure 12—Inverted Gooseneck Trap Conduit Arrangement

## 5.6 GROUNDING

### 5.6.1 Grounding of the Machinery Protection System

The responsible party as identified in Appendix B shall ensure that:

- a. The system is grounded in accordance with Article 250 of NFPA 70 and all metal components (that is, conduit, field junction boxes, and equipment enclosures) are electrically bonded (see Figure 13).
- b. All metal enclosure components are connected to an electrical grounding bus and that this electrical grounding bus is connected to the electrical grounding grid with a multi-strand AWG 4 or larger, dedicated copper ground wire.
- c. Mutual agreement is obtained from the purchaser and the machinery protection system vendor with respect to grounding, hazardous area approvals required, instrument performance, and elimination of ground loops.
- d. The transducer signal and common is isolated from the machine ground.
- e. The machinery protection system instrument common is designed to be isolated (not less than 500 Kohms) from electrical ground and installed with single-point connection to the instrument grounding system.
- f. The signal cable shield is only grounded at the monitor system.

- g. The shield is not used as the common return line.
- h. Shields are carried through any field junctions.

## 5.7 FIELD-INSTALLED INSTRUMENTS

**5.7.1** Field-installed machinery protection system installations shall be suitable for the area classification (zone or class, group, and division) specified by the purchaser and shall meet the requirements of the applicable sections of IEC 79 (NFPA 70, Articles 500, 501, 502, and 504) as well as any local codes specified and furnished on request by the purchaser. If instruments are located outdoors or are subject to fire sprinklers, their housings shall be watertight (NEMA Type 4 X), as specified in NEMA 250, in addition to any other enclosure requirements necessary for the area classification in which the instrument is installed. Nonincendive or intrinsically safe instruments are preferred (see note). When air purging is specified to meet the area classification, it shall be in accordance with ISA S12.4 or with NFPA 496, Type X, Y, or Z; as required.

Note: Explosion-proof or intrinsically safe instrumentation is acceptable for Class I, Division 1 and Division 2 hazardous (classified) locations; nonincendive instrumentation is acceptable for Class I, Division 2 hazardous (classified) locations when installed in accordance with Article 501, NFPA 70.

- **5.7.2** When specified, air purging shall be used to avoid moisture or corrosion problems, even when weatherproof or

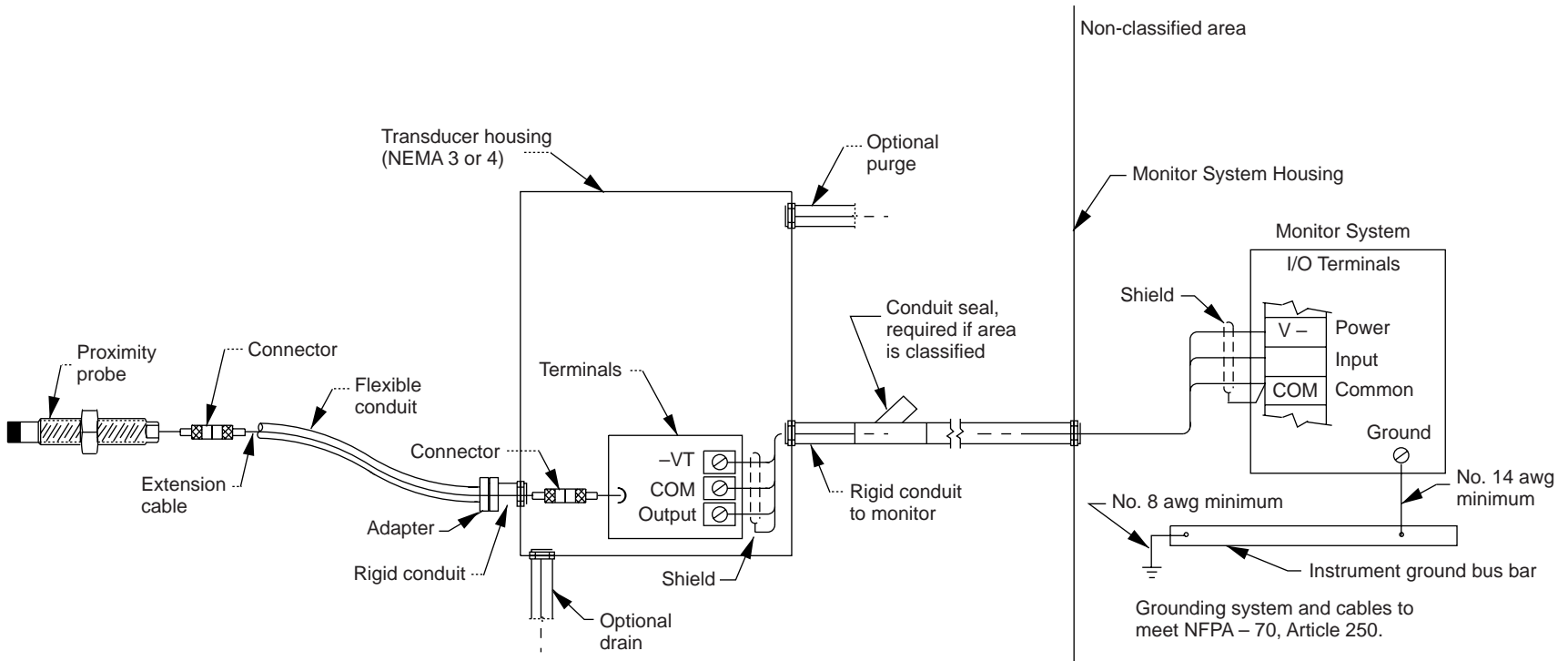

Figure 13—System Grounding (Typical)

watertight housings are used (see 5.7.1). Purge air shall be clean and dry.

**5.7.3** The satisfactory operation of electronic instrumentation in the presence of radio-frequency interference requires that both the level and the form of the interference, as well as the required degree of immunity to it, be clearly defined by the owner (one company may not allow the use of radios in a control room whereas another may allow their use behind instrument panels in the control room while the enclosures are open). Once the requirement for immunity to radio-frequency interference is defined, the details of electronic design and hardware installation can be established (see note). Unless otherwise specified, monitor systems shall comply with the electromagnetic radiation immunity requirements of EN 50082-2 and shall use metallic conduit or armored cable.

Note: In addition to sound practices in the areas of instrument design, grounding, and shielding, the use of metallic conduit or armored cable and radio-frequency interference (conductive) gasketing is critical to a successful installation. To ensure a trouble-free installation, the detailed requirements of a particular system must be discussed during the procurement phase by the machinery protection system vendor, the construction agency, and the owner. The machinery protection system vendor does not usually have control over the installation of the monitor system.

## 6 Transducer and Sensor Arrangements

### 6.1 LOCATION AND ORIENTATION

Refer to Appendix H for typical system arrangement plans showing quantities and types of transducers for various machines.

#### 6.1.1 Radial Shaft Vibration Probes

**6.1.1.1** For monitored radial bearings, two radially oriented probes shall be provided. These two probes shall be:

- a. Coplanar, 90 degrees ( $\pm 5$  degrees) apart, and perpendicular to the shaft axis ( $\pm 5$  degrees).
- b. Located 45 degrees ( $\pm 5$  degrees) from each side of the vertical center.
- c. Referenced such that when viewed from the driver end of the machine train, the Y (vertical) probe is on the left side of the vertical center, and the X (horizontal) probe is on the right side of the vertical center regardless of the direction of shaft rotation.
- d. Located within 75 millimeters (3 in.) of the bearing.
- e. Located the same with respect to the nodal points as determined by a rotor dynamic analysis of the shaft's lateral motion (for example, both sets of probes shall be either inside or outside the nodal points) (see API Recommended Practice 684).
- f. Located such that they do not coincide with a nodal point.

**6.1.1.2** The surface areas to be observed by the probes (probe areas) shall be concentric with the bearing journals

and free from stencil and scribe marks or any other mechanical discontinuity, such as an oil hole or a keyway. These areas shall not be metallized or plated. The final surface finish shall not exceed (be rougher than) 1.0 micrometer (32 microinches) root mean square, preferably obtained by diamond burnishing.

Note: Diamond burnishing has proven to be effective for electric runout reduction.

**6.1.1.3** These probe areas shall be properly demagnetized or otherwise treated so that the combined total electrical and mechanical runout does not exceed 25% of the maximum allowed peak-to-peak vibration amplitude or 6 micrometers (0.25 mil), whichever is greater (see note).

Note: Diamond burnishing with a tool-post-held, spring-mounted diamond is common. Final finishing or light surface-removal finishing by grinding will normally require follow-up demagnetization. The proximity probe area should be demagnetized. The gauss level of the proximity probe area should not exceed  $\pm 2$  gauss. The variation of gauss level around the circumference of the proximity probe area should not exceed 1 gauss.

**6.1.1.4** For all conditions of rotor axial float and thermal expansion, a minimum side clearance of one-half the diameter of the probe tip is required. The probe shall not be affected by any metal other than that of the probe area.

**6.1.1.5** Unless otherwise specified, the probe gap shall be set at  $-10.0$  volts DC ( $\pm 0.2$  volts DC).

#### 6.1.2 Axial Position Probes

- **6.1.2.1** Two axially oriented probes shall be supplied for the thrust bearing end of each casing. Both probes shall sense the shaft itself or an integral axial surface installed within an axial distance of 300 millimeters (12 in.) from the thrust bearing or bearings (see Figure 14). When specified, the standard optional arrangement shall be one probe sensing the shaft end and one probe sensing an integral thrust collar (see note).

Note: Measurement on a loose non-integral thrust collar will result in a false indication of shaft axial position.

**6.1.2.2** It shall be possible to adjust the probe gap using commercially available wrenches. No special bent or split socket wrenches shall be required. The electrical box shall protect the axial probe assembly so that external loads (for example, those resulting from personnel stepping on the box) do not impose stress on the assembly and result in false shaft-position indication (see Figure 14).

**6.1.2.3** Externally removable probes shall include provisions to indicate that the gap adjustment has not been changed from the original setting. This may be accomplished by either tie wires or external markings.

**6.1.2.4** Shaft and collar areas sensed by axial probes shall have a combined total electrical and mechanical runout of not more than 13 micrometers (0.5 mil) peak-to-peak. The provi-

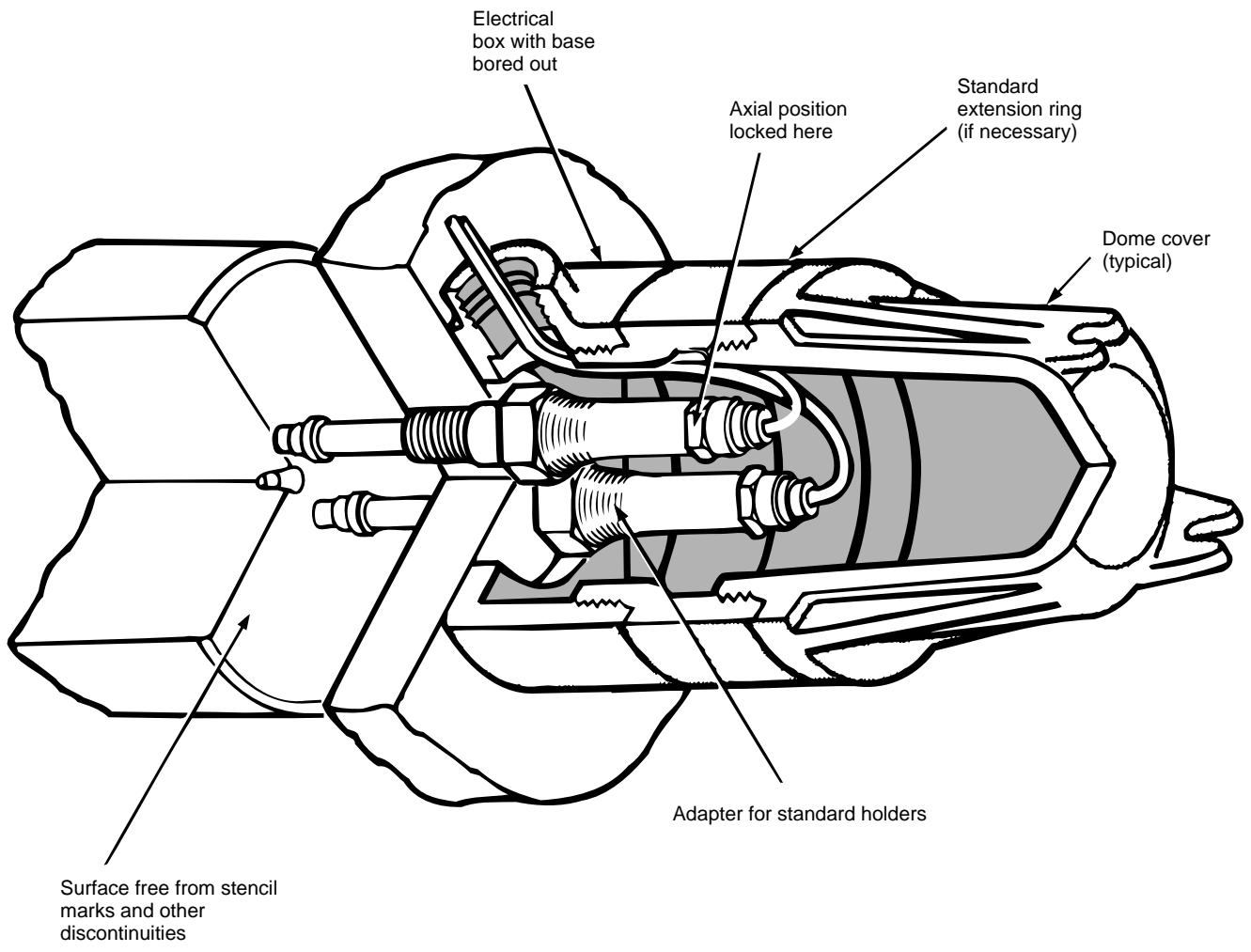

Figure 14—Standard Axial Position Probe Arrangement

sions of 6.1.1.2 regarding surface finish and the requirement of 6.1.1.4 regarding minimum side clearance shall be observed.

**6.1.2.5** The axial probe gap shall be set so that when the rotor is in the center of its thrust float, the transducer's output voltage is  $-10$  volts DC ( $\pm 0.2$  volts DC).

### 6.1.3 Piston Rod Drop Probes

**6.1.3.1** Piston rod drop probes shall be mounted internally in the distance piece with a mounting block attached to the face of the pressure packing box. The mounting bracket length shall not exceed 75 mm (3 in.). The probe area is the piston rod. Unless otherwise specified, the piston rod drop probe shall be mounted directly below the piston rod (see Figure 15).

Note: Piston rod drop measurement do not generally enable the use of reverse mount probes. A standard option forward mount probe should be selected instead.

- **6.1.3.2** When specified, the piston rod drop probe may be mounted directly over the piston rod rather than below the piston rod.

Note: This location may also be used when a redundant or spare probe is needed.

**6.1.3.3** It shall be possible to adjust the probe gap using commercially available wrenches. No special bent or split socket wrenches shall be required.

**6.1.3.4** When the piston rod is coated, the proximity probe shall be calibrated on the individual coated piston rod itself.

Note: Coated probe areas will affect system calibration and require special calibration of the probe system depending on the coating material used and the thickness.

**6.1.3.5** Unless otherwise specified, the piston rod drop probe shall be gapped as follows:

- a.  $-15$  volt DC ( $\pm 0.2$  volt DC) for bottom-mounted probes.
- b.  $-5$  volt DC ( $\pm 0.2$  volt DC) for top-mounted probes.

Discussion:

1. Piston rod drop probes need more linear range available in the piston rod drop direction than in the piston rod rise direction. Therefore, these probes should not be gapped at center range. Proper gap for these probes depends on the rider band size, the amount of piston rod rise expected due to thermal growth, and whether the probe is mounted above or below the piston rod. The position of the piston rod in a. is with the piston rod at its maximum height. The position of the piston rod in b. is with the piston rod at its minimum height.

2. The initial piston rod drop probe gap must allow the probe sufficient range to view the piston rod under the following two conditions.

- a. With new rider bands installed after allowing for thermal expansion of the piston.
- b. With the rider bands completely worn and the piston riding directly on the cylinder liner.

- **6.1.3.6** When specified, an additional probe shall be mounted in the horizontal plane to assist in diagnostics in accordance with 5.4.4.3 (see Figure 15).

Note: The convention for X and Y probes when making piston rod drop measurements is to view the probes from the crankshaft looking towards the cylinder. The probe referred to as "Y" is always located 90 degrees counterclockwise from the probe referred to as "X," regardless of what vertical or horizontal orientation they may have.

**6.1.3.7** For all conditions of machine operation and thermal expansion, a minimum side clearance of one-half the diameter of the probe tip is required. The probe shall not be affected by any metal other than that of the probe area.

### 6.1.4 Phase Reference Transducers

**6.1.4.1** A one-event-per-revolution mark and a corresponding phase reference transducer shall be provided on the driver for each machinery train (see Figure H-4 for an example), on the output shaft(s) of all gearboxes (see Figure H-2), and on reciprocating compressors when piston rod drop measurements are made (see Figure H-6).

- **6.1.4.2** When specified, a spare phase reference transducer shall be installed per 6.2.1.1.c. The radial location of a spare phase reference transducer, relative to the primary phase reference transducer, shall be documented.

Note: Loss of a phase reference transducer, when used as an input to a tachometer, results in loss of speed indication. Also, loss of a phase reference transducer results in the loss of diagnostic capabilities for all other radial and axial transducers referenced to that shaft.

**6.1.4.3** Where gearboxes are used, a one-event-per-revolution mark and a phase reference transducer shall be provided for each output shaft.

**6.1.4.4** Phase reference probe mounting requirements and electrical conduit protection shall be identical to that of a radial shaft vibration probe (see 6.2.1.1).

**6.1.4.5** The phase reference probe and its angular position shall be permanently marked with a metal tag on the outside of the machine casing. The angular position of the one-event-per-revolution mark on the rotor shall be marked on an accessible portion of the shaft.

**6.1.4.6** A change in the transducer's output voltage of at least 7 volts shall be provided for triggering external analysis equipment and digital tachometers.

**6.1.4.7** The minimum width of the marking groove shall be one and one-half times the diameter of the probe tip; the minimum length shall be one and one-half times the diameter of



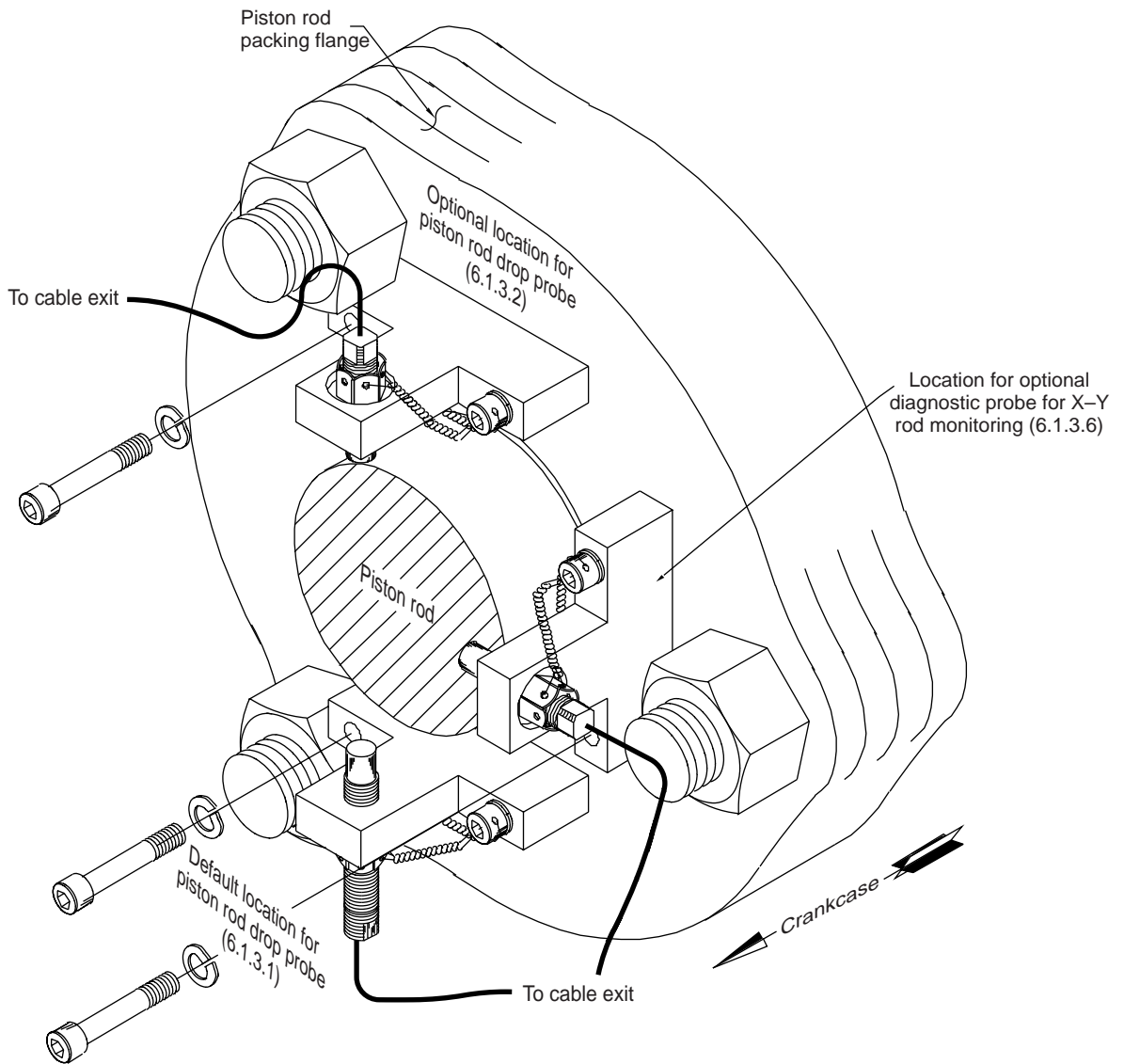

Figure 15—Typical Piston Rod Drop Probe Arrangement

the probe tip; and the minimum depth shall be 1.5 millimeters (0.06 in.). All edges shall be radiused to a minimum of 0.8 millimeter (0.03 in.). The one-event-per-revolution mark shall be long enough to allow for shaft thermal expansion and rotor float.

**6.1.4.8** Phase reference probes shall be radially mounted to sense a one-event-per-revolution mark. The mark shall not be placed in the path of the normal radial vibration probes.

### 6.1.5 Standard Tachometer Transducers

- **6.1.5.1** The phase reference transducer in 6.1.4 shall be used as the input to the tachometer. Mounting requirements and electrical conduit protection shall be identical to that of a radial shaft vibration probe (see 6.2.1.1). When specified, options include the following:

- a. The standard probe of 5.1.1.2 observing a multi-tooth speed sensing surface.
- b. The magnetic speed sensor of 5.1.5 observing a multi-tooth speed sensing surface.

Notes:

1. To achieve the required tachometer accuracy and response time, a multi-tooth speed sensing surface may be required, particularly for applications involving low shaft speeds (below 250 rpm) such as slow-roll or zero speed. Refer to Appendix J for application considerations pertaining to multi-tooth speed sensing surfaces.

2. Refer to notes following Section 6.1.6.2 for application considerations pertaining to speed sensor selection.

### 6.1.6 Electronic Overspeed Detection System Speed Sensors

**6.1.6.1** Three separate speed sensors that are not shared with any other system shall be provided for the electronic overspeed detection system.

**6.1.6.2** Unless otherwise specified, speed sensors used as inputs to the electronic overspeed detection system shall be passive magnetic speed sensors (see 5.1.5).

Notes:

1. While passive magnetic speed sensors are often employed for speed sensing, they may not allow low shaft speeds (typically below 250 rpm) to be measured, even when a multi-toothed wheel is employed. Externally-powered sensors (both active magnetic speed sensors and proximity probes) are capable of providing a signal down to shaft speeds of 1 rpm or lower and represent a better choice for these applications.

2. For applications involving overspeed sensing, powered sensors have inherent advantages over passive magnetic speed sensors and should be considered because they allow the electronic overspeed detection system to assess the integrity of its inputs more fully. They enable self-checking and circuit fault diagnostic capabilities (such as

sensor gap within acceptable range or sensor and field wiring deterioration).

3. Proximity probes can be gapped further from the speed sensing surface than active or passive magnetic speed sensors and are therefore less likely to rub and fail during abnormal rotor vibration conditions (such as encroaching on a second critical speed during an overspeed condition) when radial vibration amplitudes at the speed sensing surface location may be large.

**6.1.6.3** Mounting requirements and electrical conduit protection for speed sensors shall be identical to that required for radial shaft vibration probes (see 6.2.1.1).

**6.1.6.4** A multi-toothed surface for speed sensing shall be provided integral with, or positively attached, or locked, to the driver shaft. This surface may be shared by other speed sensors, but shall not be used as a gear for driving other mechanical components. Refer to Appendix J for typical details of this multi-toothed surface.

### 6.1.7 Accelerometers

**6.1.7.1** Accelerometers intended to monitor radial casing vibration shall be located on the radial bearing housing. Location and number of accelerometers shall be jointly developed by the machinery vendor and the owner. In some applications, field determination of the optimum mounting location may be required.

Note: Accelerometers intended to monitor axial casing vibration shall be oriented axially located on or as near as possible to the thrust bearing housing.

### 6.1.8 Bearing Temperature Sensors

#### 6.1.8.1 Radial Bearing Sensors

**6.1.8.1.1** Unless otherwise specified, temperature sensors for sleeve journal bearings shall be arranged as follows:

- a. Bearings whose length-to-diameter ratio is greater than 0.5 shall be provided with two axially collinear temperature sensors located in the lower half of the bearing, 30 degrees ( $\pm 10$  degrees) from the vertical centerline in the normal direction of rotation.
- b. Bearings whose length-to-diameter ratio is less than or equal to 0.5 shall be provided with a single sensor axially located in the center of the bearing, 30 degrees ( $\pm 10$  degrees) from the vertical centerline in the normal direction of rotation.

**6.1.8.1.2** Unless otherwise specified, temperature sensors for tilting-pad journal bearings shall be arranged as follows:

- a. Bearings whose length-to-diameter ratio is greater than 0.5 shall be provided with two axially collinear embedded temperature sensors located at the three-quarter arc length (75% of the pad length from the leading edge). For pads with self-

aligning pivots, installation in accordance with 6.1.8.1.2.b is acceptable.

b. Bearings whose length-to-diameter ratio is less than or equal to 0.5 shall be provided with a single sensor axially located in the center of the pad at the three-quarter arc length (75% of the pad length from the leading edge).

c. For bearings with load-on-pad designs, the sensor or sensors shall be located in the loaded pad (see Figure 16).

d. For bearings with load-between-pad designs, the sensor or sensors shall be located in the pad trailing the load (see Figure 17).

**6.1.8.1.3** The machinery vendor shall notify the owner when the point of minimum lubrication film thickness does

not coincide with the sensor locations specified in 6.1.8.1.1 and 6.1.8.1.2. The location of the temperature sensors shall then be mutually agreed upon by the owner and the machinery vendor.

**6.1.8.1.4** For machines such as gearboxes, the shaft operating attitude shall be considered in determining the exact location of the temperature sensors.

Note: The gearbox manufacturer should be consulted to define the normal shaft-to-bearing load points, when selecting the exact location of temperature sensors, because the position of the journal in the bearing depends on such considerations as transmitted power and direction of gear mesh.

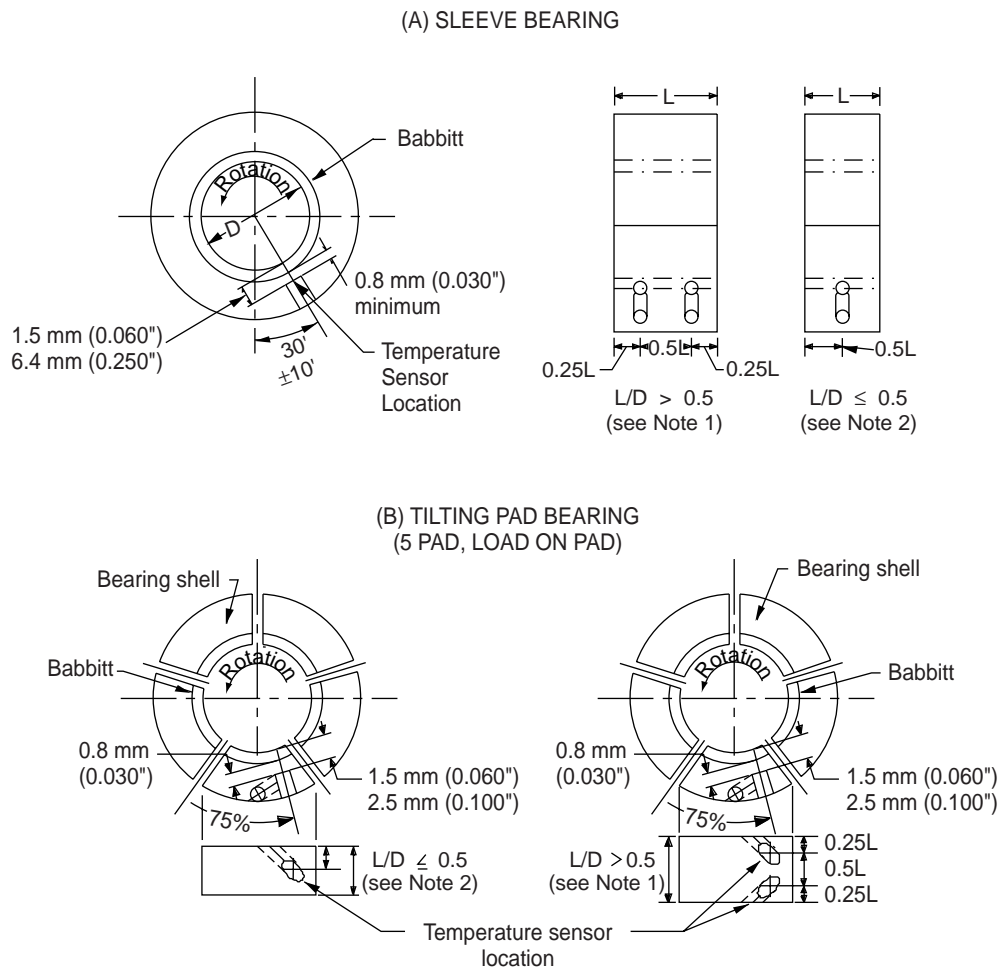

**Notes:**

1. If the length-to-diameter (L/D) ratio is greater than 0.5, two sensors shall be installed, each located at a distance of 0.25L from the end of the bearing's running face.
2. If the L/D ratio is less than or equal to 0.5, a single sensor shall be axially located in the center of the bearing.

Figure 16—Typical Installations of Radial Bearing Temperature Sensors

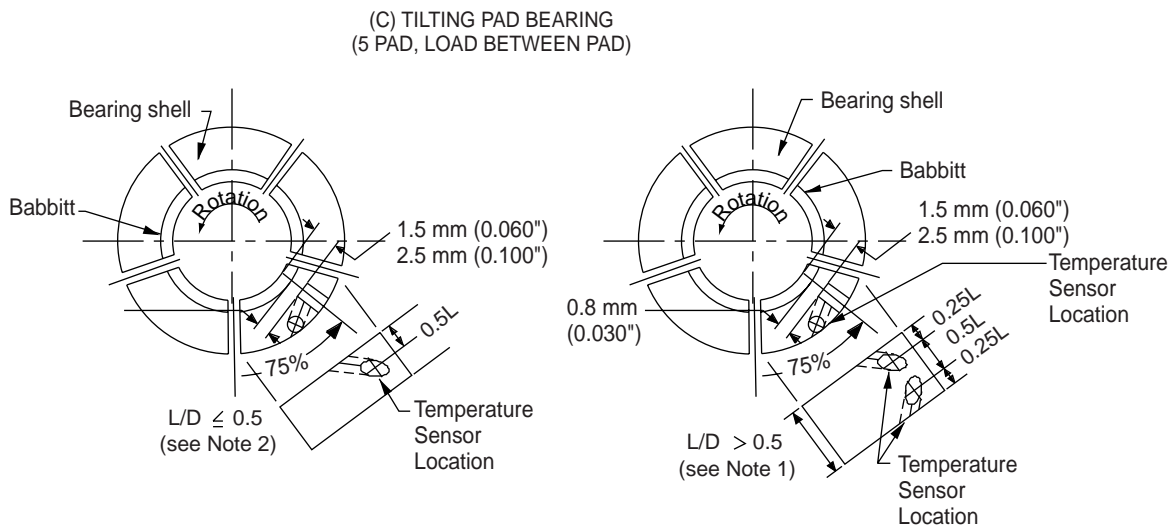

Figure 17—Typical Installations of Radial Bearing Temperature Sensors

## 6.1.8.2 Thrust Bearing Sensors

**6.1.8.2.1** A temperature sensor shall be located in each of two shoes in the normally active thrust bearing. These sensors shall be at least 120 degrees apart. For maintenance purposes and also to identify the maximum pad temperature, the sensors preferably shall be located in the lower half of the thrust bearing assembly (see Figure 18).

**6.1.8.2.2** Thrust bearing temperature sensors shall be placed at 75% of the pad width radially out from the inside bearing bore and at 75% of the pad length from the leading edge (see Figure 18).

**6.1.8.2.3** Unless otherwise specified, at least two additional temperature sensors shall be provided in the normally inactive thrust bearing, arranged as specified in 6.1.8.2.1 and 6.1.8.2.2.

## 6.2 MOUNTING

### 6.2.1 Probes

**6.2.1.1** All probes (except piston rod drop probes) shall be mounted in holders that permit adjustment and are retractable or removable while the machine is running. Internal mount-

ing of probes is acceptable only when approved by the owner or when externally mounted probes do not allow true measurement of the rotor-to-bearing relative motion but internally mounted probes do. When internal probes are used, they shall be installed with complete spares, and the location of these spares shall be approved by the owner and provided in the machinery protection system documentation. The preferred location for the installed spare probes is as follows:

a. Radial Probes—180 degrees radially from that of the installed primary probes. If this mounting location is inaccessible, spare probes shall be mounted where space permits but shall always be mounted 90 degrees apart from one another per Section 6.1.1.1.

b. Axial Probes—Spare axial probes shall be mounted to observe the same axial surface(s) as that of the installed primary probes. Their radial orientation relative to one another can vary depending on machine design.

c. Phase Reference Probes—Spare phase reference probes will ideally be at the same radial orientation as the installed primary phase reference probes. When this is not possible, they shall be located 180 degrees radially opposite the installed primary phase reference probes.

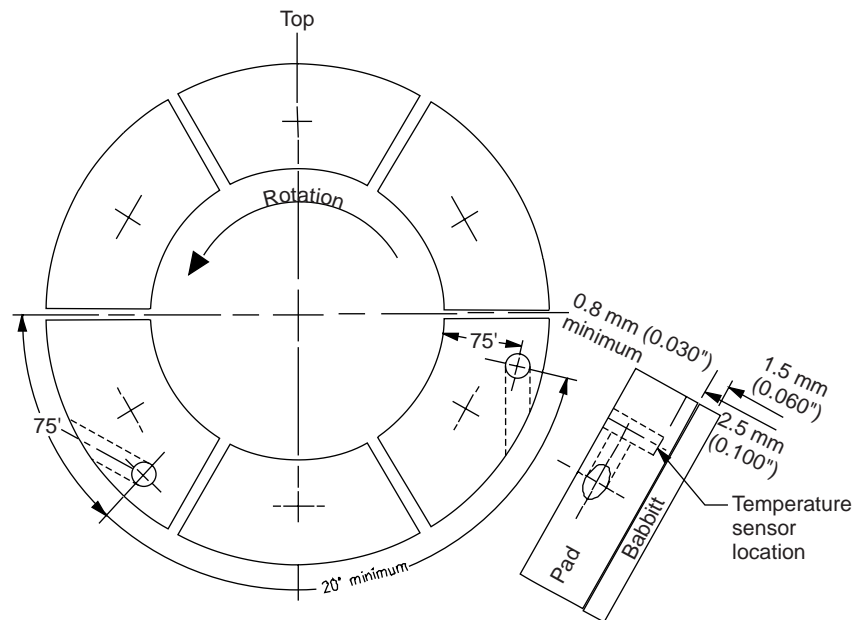

## Notes:

1. The temperature sensor shall be located 1.5 to 2.5 millimeters (0.060 to 0.100 in.) from the bearing running face and not less than 7.6 millimeters (0.030 in.) from the (white metal) babbitt/pad interface. The holes shall be finished with a bottoming drill, and all corners shall be broken.
2. The sensor lead shall be routed from the bearing to the outside of the machine through a penetration fitting. The sensor lead shall be properly secured, with no internal connections, to prevent damage as a result of whipping, chafing, windage, and oil. The sensor lead shall not restrain pivoting thrust shoes.

Figure 18—Typical Installation of Thrust Bearing Temperature Sensors

## Discussion:

1. Depending on the installation, internally mounted probes may be preferable because they can often be mounted on the bearing itself and provide true relative displacement between the bearing and the rotor. Externally mounted probes may not provide this bearing-to-rotor measurement and instead may simply provide a casing-to-rotor relative motion that is a less direct measurement of true machine behavior.

2. When constrained mounting areas do not allow spares to be installed, externally mounted probes should be used instead, or, with the owner's agreement, a single spare probe can be installed for each radial and axial bearing location.

**6.2.1.2** Probe holders shall be free from natural frequencies that could be excited by machine-generated frequencies. The free cantilevered length of a probe holder sleeve shall not exceed 200 millimeters (8 in.). Longer lengths require the use of a probe holder sleeve support guide.

**6.2.1.3** When a probe is internally mounted, the probe holder shall be at least 10 millimeters ( $\frac{3}{8}$  in.) thick. The probe lead shall be securely tied down to prevent cable whipping or chafing resulting from windage or oil. No cable connections shall be made inside the machine. To facilitate maintenance while the machine is running, all cable connections shall be made in conduit boxes located outside the machine.

- **6.2.1.4** In the standard configuration, all extension cables shall be protected in conduit as shown in Figure 10. Extension cable connectors shall be electrically isolated from conduit using an insulating sleeve or wrap located in an externally accessible junction box. When specified, armored extension cable as shown in Figure 11 shall be provided.

**6.2.2 Oscillator-Demodulators**

The number, location, and installation of mounting boxes for oscillator-demodulators shall be approved by the owner.

Unless otherwise specified, the following requirements shall be met:

- a. There shall not be less than one mounting box per machinery casing.
- b. All mounting boxes for oscillator-demodulators shall be located for ease of access and on the same side of the equipment train.
- c. These boxes shall not be mounted on the machine. The mounting location shall be selected so that minimal vibration is imparted to the oscillator-demodulator. The mounting location shall also be selected so that the oscillator-demodulators are not subjected to ambient temperatures exceeding their operating range (see Table 1).

### 6.2.3 Accelerometers

**6.2.3.1** The machinery vendor shall provide machined and finished accelerometer mounting points as shown in Appendix C. The boss or surface shall be part of the machine casing.

**6.2.3.2** Unless otherwise specified, the machinery vendor shall provide the standard accelerometer mounting configuration as shown in Appendix C for each accelerometer.

**6.2.3.3** All cables shall be enclosed in conduit. The conduit shall be attached to an enclosure, not to the accelerometer (see Appendix C for typical mounting and enclosure arrangements).

- **6.2.3.4** When specified, the accelerometer cable shall be protected by a weatherproof, flexible armor (see note) (see Appendix C for details).

Note: This permits mounting the accelerometer with mechanical protection without using conduit.

### 6.2.4 Bearing Temperature Sensors

**6.2.4.1** Embedded temperature sensors shall be provided. They shall not contact the babbitt (white metal) but shall be located in the bearing backing metal (see Figures 16, 17, and 18). Through-drilling and puddling of the babbitt is not permitted.

**6.2.4.2** The heat-sensing surface of the temperature sensor shall be in positive contact with the bearing backing metal and not less than 0.75 millimeter (30 mils) from the babbitt bond line. The recommended distances from the babbitt running face are as follows (see Figures 16, 17, and 18):

- a. For tilting-pad bearings, from 1.5 to 2.5 millimeters (60 to 100 mils).
- b. For sleeve bearings, from 1.5 to 6.4 millimeters (60 to 250 mils).

- **6.2.4.3** When specified, spring-loaded (bayonet type) temperature sensors that contact the outer shell of the bearing metal are permitted without bonding or embedment.

**6.2.4.4** The leads from all temperature sensors shall be oriented to minimize bending or movement during operation and maintenance. The sensor leads shall be secured to prevent cable whipping and chafing resulting from windage or oil without restricting pad movement. Unless otherwise specified, no sensor lead connections shall be made inside the machine (see note). To facilitate maintenance while the machine is running, a terminal head for all cable connections shall be provided outside the machine. The sensor leads shall be free from splices (see Figure 3).

Note: The default configuration does not permit connectors on temperature sensor leads inside the machine because connectors are an intermittent source of potential problems. Requiring all connections outside the machine ensures connector problems can be addressed without machine shutdown and disassembly. However, the paragraph does allow the user to specify internal connectors when required for ease of mechanical maintenance.

- **6.2.4.5** When specified, the temperature sensor tip shall be electrically insulated from the bearing (see note).

Note: Many machines, notably electric motors and generators, require electrically insulated bearings to prevent circulating shaft currents. Bearing temperature sensors must not violate this insulation requirement (see 5.3.1.1 and 5.6.1).

**6.2.4.6** The temperature sensor signal cables shall not permit liquid or gas to leak out of the point where they penetrate the bearing housing.

Acceptable arrangements include the following:

- a. Potted, encased sleeves that are sealed with compression seals.
- b. Molded signal leads within an elastomeric material that is sealed with a tapered compression fitting.
- c. Hermetic seals.
- d. Inverted gooseneck trap arrangement in conduit (see Figure 12).

## 6.3 IDENTIFICATION OF TRANSDUCERS AND TEMPERATURE SENSORS

Each probe lead, extension cable, oscillator-demodulator, and temperature sensor lead shall be plainly marked to indicate the location and service of its associated probe or sensor. This tagging shall be visible without disassembly of machine or removal from machine.

## 7 Inspection, Testing, and Preparation for Shipment

### 7.1 GENERAL

**7.1.1** After advance notification of the machinery protection system vendor by the purchaser, the purchaser's representative shall have entry to all vendor and subvendor plants where manufacturing, testing, or inspection of the equipment is in progress.

**7.1.2** The machinery protection system vendor shall notify subvendors of the purchaser's inspection and testing requirements.

**7.1.3** The machinery protection system vendor shall provide sufficient advance notice to the purchaser before conducting any inspection that the purchaser has specified to be witnessed or observed.

- **7.1.4** The purchaser will specify the extent of his participation in the inspection and testing, and the amount of advance notification he requires.

**7.1.4.1** When shop inspection and testing have been specified by the purchaser, the purchaser and the machinery protection system vendor shall meet to coordinate hold points and inspectors' visits.

**7.1.4.2** *Witnessed* means that a hold shall be applied to the production schedule and that the inspection or test shall be carried out with the purchaser or his representative in attendance. For factory acceptance testing of the machinery protection system, this requires written notification of a successful preliminary test.

**7.1.4.3** *Observed* means that the purchaser shall be notified of the timing of the inspection or test; however, the inspection or test shall be performed as scheduled, and if the purchaser or his representative is not present, the machinery protection system vendor shall proceed to the next step. (The purchaser should expect to be in the factory longer than for a witnessed test.)

**7.1.5** Equipment for the specified inspection and tests shall be provided by the machinery protection system vendor.

**7.1.6** The purchaser's representative shall have access to the machinery protection system vendor's quality control program for review.

## 7.2 INSPECTION

The machinery protection system vendor shall keep the following data available in electronic format for at least 20 years for examination by the purchaser or his representative upon request:

- a. Purchase specifications for all major items on bills of materials.
- b. Test and calibration data to verify that the requirements of the specification have been met.

## 7.3 TESTING

### 7.3.1 General

**7.3.1.1** Equipment shall be tested in accordance with 7.3.2.

**7.3.1.2** The machinery protection system vendor shall notify the purchaser not less than 5 working days before the

date the equipment will be ready for testing. If the testing is rescheduled, the machinery protection system vendor shall notify the purchaser not less than 5 working days before the new test date.

## 7.3.2 Machinery Protection System Vendor Testing

**7.3.2.1** As a minimum, the machinery protection system vendor shall individually bench test each component of the monitor system to ensure compliance with the accuracy requirements of Table 1.

- **7.3.2.1.1** When specified, a factory acceptance test of the machinery protection system shall be conducted. Details of this test shall be mutually agreed upon by the machinery protection system vendor and the owner.

Note: This test may include (but is not limited to) integration with process control, emergency shutdown, machinery data acquisition and diagnostic, or other systems; simulation of transducer system inputs and proper operation of output, display and communication capabilities.

**7.3.2.2** The machinery protection system vendor shall have test documentation and certification available for inspection by the purchaser.

## 7.4 PREPARATION FOR SHIPMENT

**7.4.1** The machinery protection system vendor shall provide the purchaser with the instructions necessary to preserve the integrity of the storage preparation after the equipment arrives at the job site and before start-up.

**7.4.2** The equipment shall be prepared for shipment after all testing and inspection have been completed and the equipment has been released by the purchaser.

**7.4.3** The equipment shall be identified with item and serial numbers. Material shipped separately shall be identified with securely affixed, corrosion-resistant metal tags indicating the item and serial number of the equipment for which it is intended. Where the equipment does not provide sufficient room for attachment of metal tags, a mutually agreed upon means for indicating item and serial number shall be used. In addition, crated equipment shall be shipped with duplicate packing lists, one on the inside and one on the outside of the shipping container.

**7.4.4** One copy of the manufacturer's standard installation instructions shall be packed and shipped with the equipment.

- **7.4.5** The purchaser shall specify to the vendor any specialized requirements for packing, sealing, marking, or storage of the equipment.

## 7.5 MECHANICAL RUNNING TEST

Unless otherwise specified, transducer systems of the same type and manufacture as those purchased for the installation

shall be in use during the factory mechanical running test of monitored equipment.

## 7.6 FIELD TESTING

**7.6.1** All features of the monitor system specified in 5.4 shall be functionally tested by the construction agency (see Appendix F). Results shall be documented in accordance with 8.3. The construction agency shall verify that the alarm (alert) and shutdown (danger) setpoints are adjusted to the values agreed upon by the purchaser.

**7.6.2** Each monitor system shall be tested in the field to verify calibration in the testing temperature range (see 4.1). These tests shall be conducted in accordance with 7.6.2.1, 7.6.2.2, and 7.6.2.3 by the construction agency using the actual monitoring system components to be installed on the machine. Results shall be documented in accordance with 8.3 (see note).

Note: Figures 19 and 20 illustrate typical overall system functions.

- **7.6.2.1** For proximity probe transducer systems, a graph of the gap (a minimum of 10 points in either micrometers or mils) versus the transducer's output voltage shall be provided by the construction agency and supplied to the owner (see Figure 21). This procedure shall be performed in accordance with the requirements of the machinery protection system vendor (see Appendix G). When specified, calibration to the installed probe area shall be performed.

**7.6.2.2** Temperature monitors shall be tested by substitution of the job temperature sensor with an appropriate sensor simulator. A minimum of three points (20%, 50%, and 80% of span) shall be simulated and the monitor readings recorded.

**7.6.2.3** For casing vibration systems, a shaker simultaneously exciting the job accelerometer and a calibrated reference accelerometer shall be used for testing. The accelerometer shall be tested over the frequency and amplitude ranges listed in Tables 3A and 3B. The monitor system shall be tested to full-scale amplitude by electronic simulation.

**7.6.2.4** For tachometer and electronic overspeed detection systems, the monitor system shall be tested to full-scale range by electronic simulation.

**7.6.3** The construction agency shall perform a field test of the entire machinery protection system to verify operation to design specification requirements. This test shall include system performance and functionality of its integration with other control, automation, and information systems. Details of this test shall be mutually agreed upon by the construction agency and the owner. Results shall be documented in accordance with 8.3.

Note: This test may include (but is not limited to) integration with process control, emergency shutdown, machinery data acquisition and diagnostic, or other systems; simulation of transducer system inputs and proper operation of output, display, and communication capabilities.

## 8 Vendor's Data

### 8.1 GENERAL

**8.1.1** The information required in this section shall be furnished by the machinery vendor with unit responsibility or by the responsible agency specified in Appendix B. The machinery vendor shall complete and forward the Vendor Drawing and Data Requirements form to the address or addresses noted on the inquiry or order (see Appendix G). This form shall detail the schedule for transmission of drawings, curves, and data as agreed to at the time of the order, as well as the number and type of copies required by the purchaser.

**8.1.2** The data shall be identified on transmittal (cover) letters and in title blocks or title pages with the following information: The purchaser/owner's corporate name.

- c. The job/project number.
- d. The equipment item or tag number and service name.
- e. The purchase order number.
- f. Any other identification specified in the inquiry or purchase order.
- g. The machinery vendor's identifying proposal number, shop order number, serial number, or other reference required to identify return correspondence completely.

**8.1.3** A coordination meeting covering the API 670 Machinery Protection System shall be held (preferably at the entity holding unit responsibility for the entire machinery train in the case of new machines), within 4 to 6 weeks after the purchase commitment.

Unless otherwise specified, the machinery vendor having unit responsibility will prepare and distribute an agenda prior to this meeting, which, as a minimum, shall include review of the following items relative to the API 670 Machinery Protection System:

- a. The purchase order, scope of supply, unit responsibility, and subvendor's items.
- b. The datasheets.
- c. Applicable specifications and previously agreed-upon exceptions.
- d. Schedules for transmittal of data, production, and testing.
- e. The quality assurance program and procedures.
- f. Inspection, expediting, and testing.
- g. Schematics and bills of material.
- h. The physical orientation of the rotating equipment with relation to the API 670 system components.
- i. Other technical items.



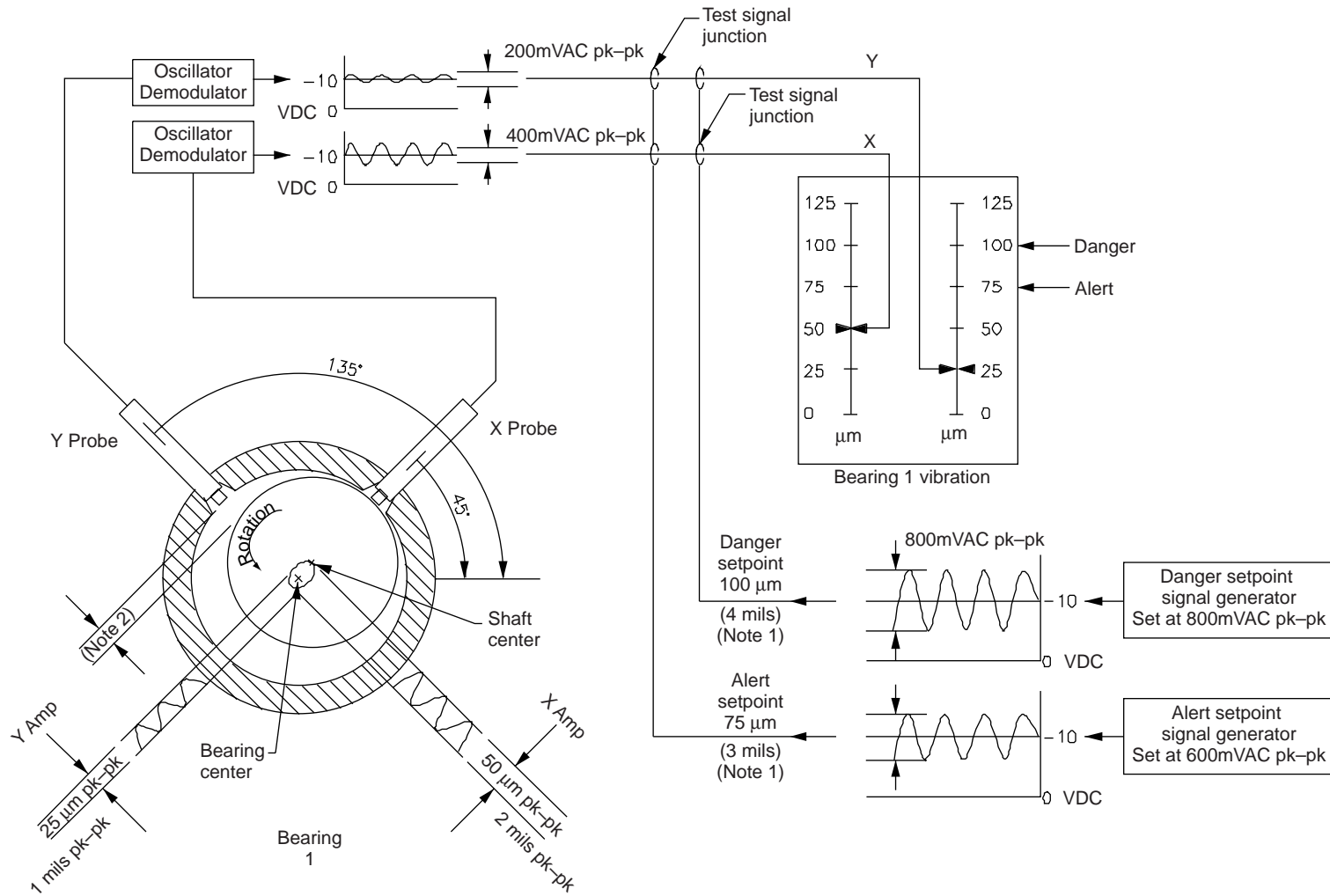

**Notes:**

1. The example shown is for illustration only and does not necessarily represent any actual condition or machine.
2. Probe cold gap setting is typically 1250  $\mu\text{m}$  (50 mils), which corresponds to approximately 10 volts DC.

Figure 19—Calibration of Radial Monitor and Setpoints for Alarm and Shutdown

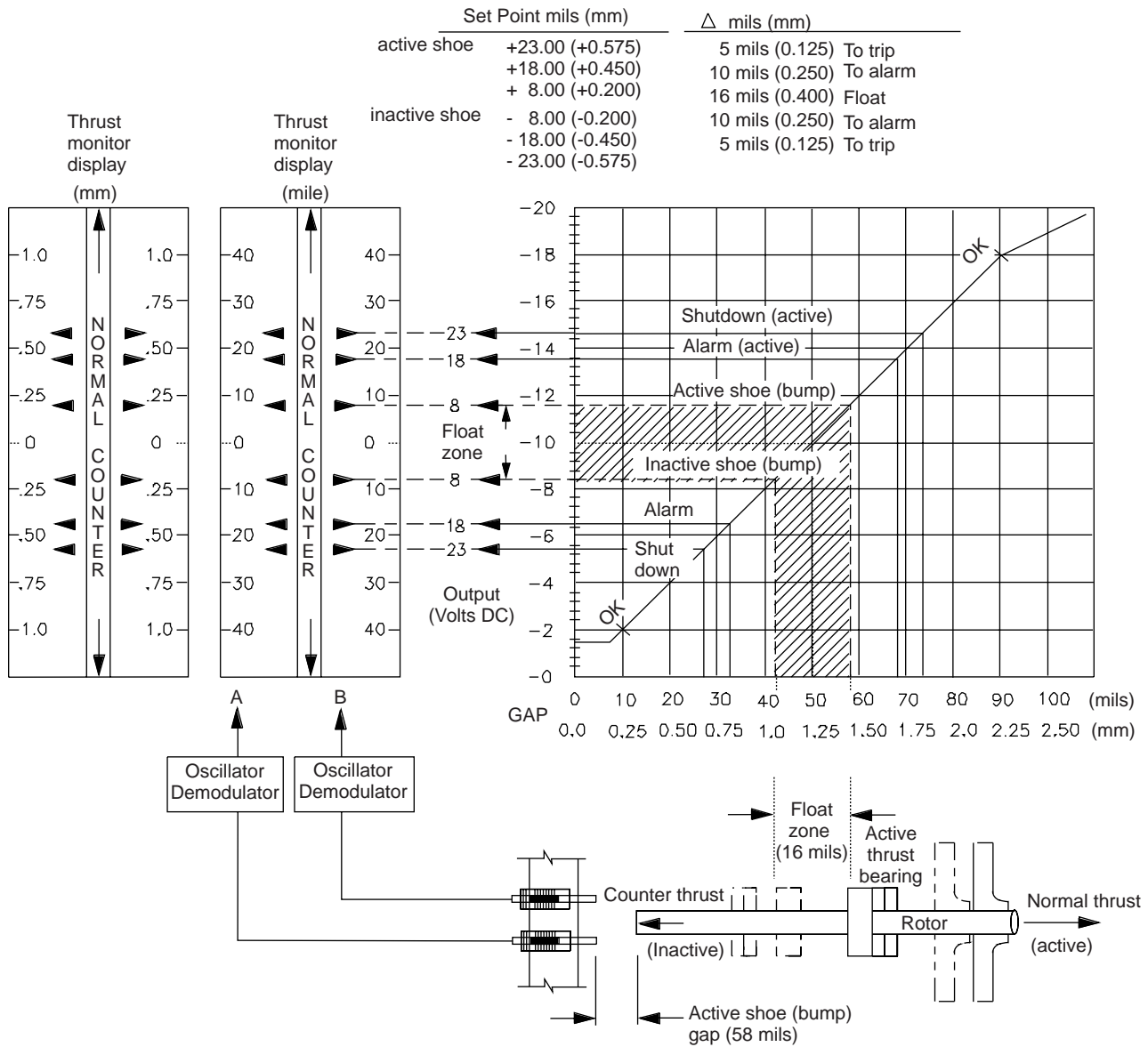

Notes:

1. The monitor is calibrated for 200 millivolts per mil and has a cold float zone of 16 mils. The monitor's range is from +40 mils to -40 mils. The calibration procedure consists of the following steps: (1) assuring the calibration curve, (2) bumping the shaft to the active shoe, (3) adjusting the probe for a meter indication of 8 mils (a transducer output of approximately 11.6 volts DC), (4) bumping the float to confirm the thrust, and (5) setting the alarm and shutdown points.
2. The example shown is for illustration purposes only and does not necessarily represent any actual condition or machine.

Figure 20—Calibration of Axial Position (Thrust) Monitor

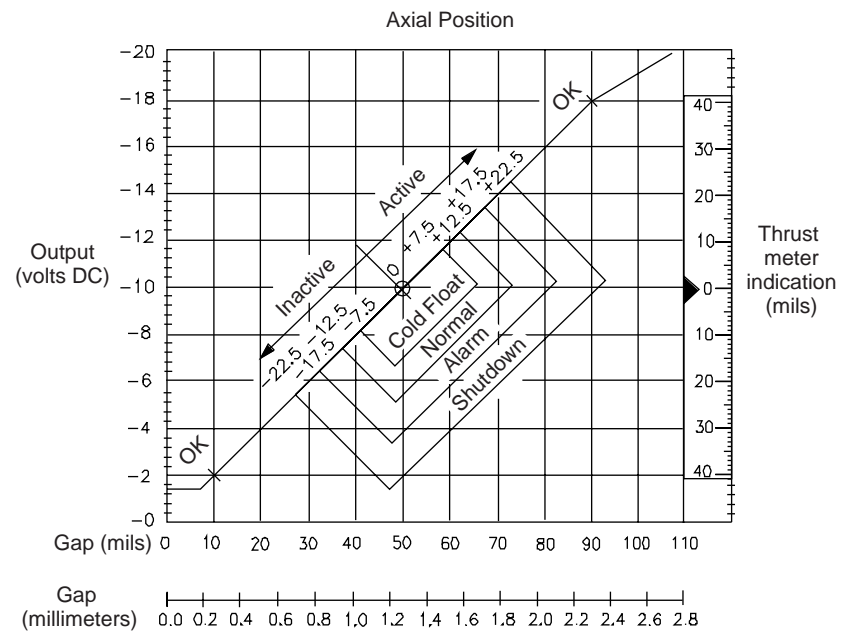
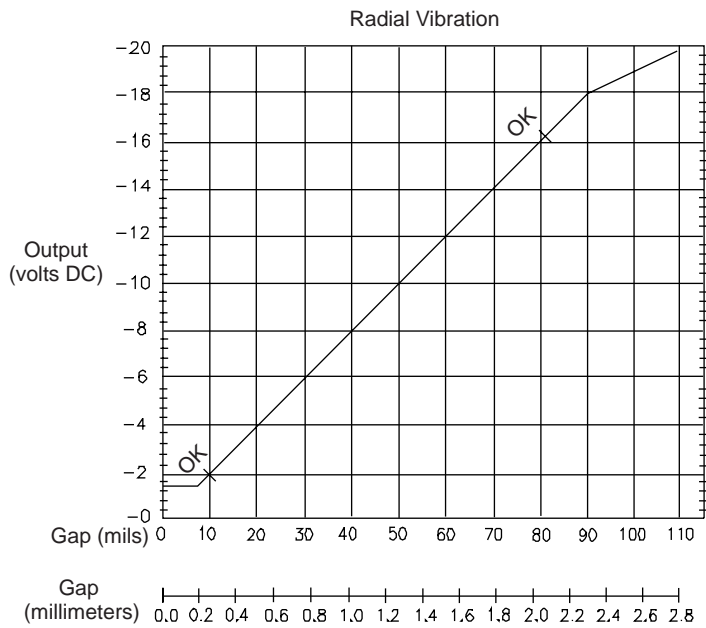

Calibration	Output	Machine Tag Number: _____
Gap (mils)	(volts DC)	Probe Tag Number: _____
10	-2.0	Probe Serial Number: _____
20	-4.0	Model: _____
30	-6.0	Extension Cable Number: _____
40	-8.0	Probe Resistance (ohm): _____
50	-10.0	Probe and Cable Resistance (ohm): _____
60	-12.0	Oscillator-Demodulator:
70	-14.0	Type/Serial Number: _____
80	-16.0	Supply Voltage: _____
90	-18.0	Cold Gap Set: _____
		Alarm Set Point: _____
		Shutdown Set Point: _____
		Date: _____

Note: Referenced to 200 millivolts

Output	Meter	Machine Tag Number: _____
(volts DC)	Indication	Probe Tag Number: _____
-2.0	-40	Probe Serial Number: _____
-4.0	-30	Model: _____
-6.0	-20	Extension Cable Number: _____
-8.0	-10	Probe Resistance (ohm): _____
-10.0	0	Probe and Cable Resistance (ohm): _____
-12.0	+10	Oscillator-Demodulator:
-14.0	+20	Type/Serial Number: _____
-16.0	+30	Supply Voltage: _____
-18.0	+40	Cold Gap Set: _____
		Alarm Set Point: _____
		Shutdown Set Point: _____
		Date: _____

Note: Referenced to 200 millivolts

Figure 21—Typical Field Calibration Graph for Radial Vibration and Axial Position

Table 3A—Accelerometer Test Points (SI)

Frequency (Hz)	Acceleration		Velocity	
	m/sec <sup>2</sup> rms	m/sec <sup>2</sup> peak	mm/sec rms	mm/sec peak
10 <sup>a</sup>	1	1.41	15.92	22.51
20	7	9.90	55.70	78.78
50	7	9.90	22.28	31.51
100 <sup>a</sup>	7	9.90	11.14	15.76
159.15 <sup>b</sup>	7	9.90	7.00	9.90
200	7	9.90	5.57	7.88
500	7	9.90	2.23	3.15
1000 <sup>a</sup>	7	9.90	1.11	1.58
1000	15	21.21	2.39	3.38
2000	30	42.43	2.39	3.38
5000 <sup>a</sup>	30	42.43	0.95	1.35
10,000	30	42.43	0.48	0.68

Notes: All values are based on sinusoidal waveforms.

<sup>a</sup>These values are required test points.

<sup>b</sup>At 159.15 Hz, 1.0 m/sec<sup>2</sup> = 1.0 mm/sec (crossover frequency).

## 8.2 PROPOSALS

### 8.2.1 General

**8.2.2** The machinery vendor shall forward the original proposal and the specified number of copies to the addressee specified in the inquiry documents. As a minimum, the proposal shall include the data specified in 8.2.2 and 8.2.3, as well as a specific statement that the system and all its components are in strict accordance with this standard. If the system and components are not in strict accordance, the machinery vendor shall include a list that details and explains each deviation. The machinery vendor shall provide details to enable the purchaser to evaluate any proposed alternative designs. All correspondence shall be clearly identified in accordance with 8.1.2.

### 8.2.3 Drawings

**8.2.3.1** The drawings indicated on the Vendor Drawings and Data Requirements form shall be included in the proposal (see Appendix G). As a minimum, the following data shall be furnished:

- A general arrangement or outline drawing for each monitoring system, including overall dimensions, installation details, and maintenance clearance dimensions.
- Schematics of all control and electrical systems. Bills of materials shall be included.

**8.2.3.2** If typical drawings, schematics, and bills of materials are used, they shall be marked up to reflect the actual

Table 3B—Accelerometer Test Points (Customary Units)

Frequency (Hz)	Acceleration		Velocity	
	g peak	g rms	ips peak	ips rms
10 <sup>a</sup>	0.15	0.11	0.92	0.65
20	1	0.71	3.08	2.17
50	1	0.71	1.23	0.87
61.44 <sup>b</sup>	1	0.71	1.00	0.71
100 <sup>a</sup>	1	0.71	0.62	0.43
200	1	0.71	0.31	0.22
500	1	0.71	0.12	0.09
1000 <sup>a</sup>	1	0.71	0.06	0.04
1000	2	1.41	0.12	0.09
2000	4	2.83	0.12	0.09
5000 <sup>a</sup>	4	2.83	0.05	0.03
10,000	4	2.83	0.02	0.02

Notes: All values are based on sinusoidal waveforms.

<sup>a</sup>These values are required test points.

<sup>b</sup>At 61.44 Hz, 1 g = 1.0 ips (crossover frequency).

equipment and scope proposed and shall have the same specific project information as noted in 8.1.2 a-f.

### 8.2.4 Technical Data

The following data shall be included in the proposal:

- The purchaser's datasheets, with complete machinery vendor's information entered thereon and literature to fully describe details of the offering.
- The Vendor Drawing and Data Requirements form, indicating the schedule according to which the machinery vendor agrees to transmit all the data specified as part of the contract (see Appendix G).
- A schedule for shipment of the equipment, in weeks after receipt of the order.
- A list of spare parts recommended for startup and normal maintenance purposes.
- A list of the special tools furnished for maintenance. The machinery vendor shall identify any metric items included in the offering.
- A statement of any special weather protection and winterization required for start-up, operation, and periods of idleness under the site conditions specified. The statement shall show the protection to be furnished by the purchaser, as well as that included in the machinery vendor's scope of supply.
- A description of any special requirements specified in the purchaser's inquiry and as noted by bulleted paragraphs in Sections 5.4 and 7.4.5.

h. A description of how the system meets specified area classification requirements, as discussed in 5.7.1.

i. Any special requirements or restrictions necessary to protect the integrity of the machinery protection system.

### **8.3 CONTRACT DATA**

#### **8.3.1 General**

**8.3.1.1** The contract data specified in Appendix G shall be furnished by the machinery vendor or responsible agency specified in Appendix B. Each drawing, bill of material, and datasheet shall have a title block in its lower right-hand corner that shows the date of certification, a reference to all identification data specified in 8.1.2, the revision number and date, and the title.

**8.3.1.2** The purchaser will promptly review the machinery vendor's data when he receives them; however, this review shall not constitute permission to deviate from any requirements in the order unless specifically agreed upon in writing. After the data have been reviewed, the machinery vendor shall furnish certified copies in the quantity specified.

#### **8.3.2 Drawings**

**8.3.2.1** The drawings furnished shall contain sufficient information so that with the drawings and the manuals specified in 8.3.5, the construction agency or owner can properly install, operate, and maintain the ordered equipment. Drawings shall be clearly legible, shall be identified in accordance with 8.3.1.1, and shall be in accordance with ASME Y14.2M. As a minimum, each drawing shall include the details for that drawing listed in Appendix G.

#### **8.3.3 Technical Data**

**8.3.3.1** The data shall be submitted in accordance with Appendix G and identified in accordance with 8.3.1.1. Any comments on the drawings or revisions of specifications that necessitate a change in the data shall be noted by the machinery vendor. These notations will result in the purchaser's issue of completed, corrected datasheets as part of the order specifications.

#### **8.3.4 Parts Lists and Recommended Spares**

**8.3.4.1** The machinery vendor shall submit complete parts lists for all equipment and accessories supplied. The lists shall include manufacturer's unique part numbers, materials of construction, and delivery times. Materials shall be identified as specified in Section 5. Each part shall be completely identified and shown on cross-sectional or assembly-style drawings so that the purchaser may determine the interchangeability of the part with other equipment. Parts that have been modified from standard dimensions or finish to satisfy specific performance require-

ments shall be uniquely identified by part number for interchangeability and future duplication purposes. Standard purchased items shall be identified by the original manufacturer's name and part number.

**8.3.4.2** The machinery vendor shall indicate on the above parts lists which parts are recommended spares for start-up and which parts are recommended for normal maintenance (see Item d of 8.2.3). The machinery vendor shall forward the lists to the purchaser promptly after receipt of the reviewed drawings and in time to permit order and start-up. The transmittal letter shall be identified with the data specified in 8.1.2.

### **8.3.5 Installation, Operation, Maintenance, and Technical Data Manuals**

#### **8.3.5.1 General**

The machinery vendor shall provide sufficient written instructions and a list of all drawings to enable the purchaser and the owner to correctly install, operate, and maintain all of the equipment ordered. This information shall be compiled in a manual or manuals with a cover sheet that contains all reference-identifying data specified in 8.1.2, an index sheet that contains section titles, and a complete list of referenced and enclosed drawings by title and drawing number. The manual shall be prepared for the specified installation; a typical manual is not acceptable.

#### **8.3.5.2 Installation Manual**

Any special information required for proper installation design that is not on the drawings shall be compiled in a manual that is separate from the operating and maintenance instructions. This manual shall be forwarded at a time that is mutually agreed upon in the order, or at the time of the final issue of prints. The manual shall contain information such as special calibration procedures and all other installation design data, including the data specified in 8.2.2 and 8.2.3.

#### **8.3.5.3 Operating and Maintenance Manual**

The manual containing operating and maintenance data shall be forwarded no more than 2 weeks after all of the specified tests have been successfully completed. This manual shall include a section that provides special instructions for operation at specified extreme environmental conditions, such as temperatures. As a minimum, the manual shall also include all of the data listed in Appendix G.

#### ● **8.3.5.4 Technical Data Manual**

When specified, the machinery vendor shall provide the purchaser with a technical data manual within 30 days of completion of shop testing (see Appendix G for detail requirements).



**APPENDIX A—MACHINERY PROTECTION SYSTEM  
DATA SHEETS**





# MACHINERY PROTECTION SYSTEM DATA SHEET

PAGE \_\_\_\_\_ OF \_\_\_\_\_

JOB NO. \_\_\_\_\_ ITEM NO. \_\_\_\_\_  
 PURCH. ORDER NO. \_\_\_\_\_ DATE \_\_\_\_\_  
 INQUIRY NO. \_\_\_\_\_ BY \_\_\_\_\_  
 REVISION NO. \_\_\_\_\_ DATE \_\_\_\_\_

1	APPLICABLE TO:	<input type="radio"/> PROPOSAL <input type="radio"/> PURCHASE <input type="radio"/> AS BUILT	DATE _____	REVISION _____
2	FOR _____		UNIT _____	
3	SITE _____			
4	SERVICE _____			
5	INSTRUMENT MANUFACTURER _____			
6	NOTE:	<input type="radio"/> INDICATES INFORMATION TO BE COMPLETED BY PURCHASER	<input type="checkbox"/> BY MACHINERY VENDOR	
7		<input checked="" type="checkbox"/> BY PURCHASER OR MACHINERY VENDOR		
8	<b>MACHINERY TRAIN COMPONENTS</b>		<b>OPERATING ENVIRONMENT</b>	
9	NUMBER OF:		<input type="radio"/> STANDARD COMPONENTS (4.4) _____	
10	____ PUMPS	____ ROTARY COMPRESSIONS	<input type="radio"/> SPECIFIED CHEMICALS (4.4.2) _____	
11	____ STEAM TURBINES	____ GEAR UNITS	<input type="radio"/> SHOCK _____	
12	____ GAS TURBINES	____ ELECTRIC MOTORS	<b>PROBE DATA (5.1.1)</b>	
13	____ CENTRIFUGAL COMPRESSIONS	____ OTHER (DESCRIBE) _____	<input type="radio"/> STD. 7.6-8.3 mm TIP DIA. REV. MOUNT WITH 1.0 METER INTEGRAL CABLE (5.1.1.2)	
14	____ RECIPROCATING COMPRESSOR _____		<input type="radio"/> OPTIONAL PROBES WITH THE FOLLOWING STANDARD OPTIONS: (5.1.1.3)	
15	<b>SCOPE OF RESPONSIBILITIES</b>		<input type="radio"/> 7.6 TO 7.9 mm (0.300 TO 0.312 INCHES)	
16	<input type="radio"/> APPENDIX B _____		PROBE TIP WITH 3/8-24-UNF-2A PROBE THREADS (5.1.1.3a)	
17	<input type="radio"/> FINAL INSTALLATION _____		<input type="radio"/> 4.8-5.3 mm (0.190-0.208 INCHES) 1/4-28 UNF-2A (5.1.1.3b)	
18	<input type="radio"/> MONITOR SYSTEM _____		<input type="radio"/> TIP DIAMETER OF 7.6 TO 7.9 mm WITH M10 METRIC THREADS (5.1.1.3c)	
19	<input type="radio"/> SIGNAL CABLES _____		<input type="radio"/> TIP DIAMETER OF 4.8 TO 5.0 mm AND M8 METRIC THREADS (5.1.1.3d)	
20	<input type="radio"/> TRANSDUCERS & SENSORS _____		<input type="radio"/> LENGTHS OTHER THAN APPROXIMATELY 25 mm (1 INCH) (5.1.1.3e)	
21	<input type="radio"/> APPENDIX F REQUIREMENTS _____		<input type="radio"/> FLEXIBLE STAINLESS STEEL ARMORING ATTACHED TO THE PROBE	
22			BODY AND EXTENDING TO APPROXIMATELY 100 mm (4 INCHES) OF	
23	<b>SCOPE OF SUPPLY</b>		THE CONNECTOR (5.1.1.3f)	
24	<input type="radio"/> TRANSDUCERS _____		<input type="radio"/> STANDARD MAGNETIC SPEED SENSOR (5.1.5.1)—SEE OVERSPEED	
25	<input type="radio"/> SENSORS _____		SENSOR DATA SHEETS	
26	<input type="radio"/> MONITOR SYSTEMS _____		<input type="radio"/> OTHER (DESCRIBE) _____	
27				
28	<b>SITE DATA</b>			
29	DESIGN TEMP. °C OR °F _____ SUMMER MAX. _____ WINTER MIN. _____			
30	DESIGN WET BULB TEMP. °C OR °F _____			
31	<input type="radio"/> WINTERIZATION REQUIRED			
32	<input type="radio"/> TROPICALIZATION REQUIRED    MONITOR SYSTEMS (5.4.1.11)			
33	<input type="radio"/> UNUSUAL CONDITIONS		<input type="radio"/> INDOORS	
34	<input type="radio"/> DUST		<input type="radio"/> OUTDOORS	
35	<input type="radio"/> FUMES			
36	<input type="radio"/> OTHER (DESCRIBE) _____			
37				
38	ELECTRICAL EQUIPMENT HAZARD CLASS _____			
39	CLASS _____ GROUP _____ DIVISION _____			
40	<input type="radio"/> RADIO FREQUENCY INTERFERENCE (3.8.4) _____			
41				
42	<b>OPERATING TEMPERATURE RANGE</b>			
43	<input type="radio"/> STANDARD, ALL COMPONENTS (4.1)			
44	<input type="radio"/> NONSTANDARD REQUIREMENTS			
45	<input type="radio"/> PROBE & EXTENSION CABLE	°C OR °F FROM _____ TO _____		
46	<input type="radio"/> OSCILLATOR-DEMODULATOR	°C OR °F FROM _____ TO _____		
47	<input type="radio"/> TEMP. SENSOR & LEAD	°C OR °F FROM _____ TO _____		
48	<input type="radio"/> MONITOR AND POWER SUPPLY	°C OR °F FROM _____ TO _____		
49	<input type="radio"/> ACCELEROMETER	°C OR °F FROM _____ TO _____		
50				
51				
			<b>NUMBER OF PROBES IN TRAIN</b>	
			<input type="radio"/> STANDARD COMPLEMENT (APPENDIX __ )	
			<input type="radio"/> NONSTANDARD COMPLEMENT REQUIRED	
			PRIMARY RADIAL _____	
			SPARE RADIAL _____	
			PRIMARY AXIAL _____	
			SPARE AXIAL _____	
			PHASE REFERENCE _____	
			SPEED INDICATING _____	
			OVERSPEED SENSING _____	
			SPARE OVERSPEED SENSING _____	
			ROD DROP _____	
			<b>PROBE ARRANGEMENT (APPENDIX H)</b>	
			RADIAL TRANSDUCERS	
			<input type="radio"/> STANDARD ARRANGEMENT (6.1.1)	
			<input type="radio"/> DEVIATION FROM STANDARD RADIAL PROBE ARRANGEMENT	
			REQUIRED: (DESCRIBE) _____	
			_____	
			_____	

# MACHINERY PROTECTION SYSTEM DATA SHEET

PAGE \_\_\_\_\_ OF \_\_\_\_\_

JOB NO. \_\_\_\_\_ ITEM NO. \_\_\_\_\_  
 PURCH. ORDER NO. \_\_\_\_\_ DATE \_\_\_\_\_  
 INQUIRY NO. \_\_\_\_\_ BY \_\_\_\_\_  
 REVISION NO. \_\_\_\_\_ DATE \_\_\_\_\_

1	<b>PROBE ARRANGEMENT (APPENDIX H) (CON'T)</b>	<b>PIEZOELECTRIC ACCELEROMETER DATA (5.2) (CON'T)</b>
2	AXIAL TRANSDUCERS (6.1.2)	<input type="radio"/> ACCELEROMETER WITH THE FOLLOWING OPTIONS: (5.2.1.1.4)
3	<input type="radio"/> STANDARD SHAFT END OR INTEGRAL AXIAL SURFACE	<input type="radio"/> CENTER-POST MTG—ENGLISH THREADS OTHER THAN 1/4-26 UNF (5.2.1.1.4b)
4	<input type="radio"/> OPT. ONE PROBE ON SHAFT & ONE PROBE ON INTEGRAL THRUST COLLAR	SPECIFY THREADS _____
5	<input type="radio"/> OTHER (DESCRIBE) _____	<input type="radio"/> CENTER-POST MOUNTING—METRIC THREADS (5.2.1.1.4c)
6	_____	SPECIFY THREADS _____
7	<input checked="" type="checkbox"/> PROBES MOUNTED TO MEASURE INCREASING GAP FOR NOR. OP. (5.4.3.5)	<input type="radio"/> INTEGRAL EXTENSION CABLE (5.2.1.1.4d)
8	<input checked="" type="checkbox"/> PROBES MOUNTED TO MEASURE DECREASING GAP FOR NOR. OP. (5.4.3.5)	<input type="radio"/> INTEGRAL CENTER POST (5.2.1.1.4a)
9	PHASE REFERENCE TRANSDUCERS/ONE EVENT PER REVOLUTION	<input type="radio"/> STANDARD 5 METER (200 INCH) ACCELEROMETER EXTENSION CABLE
10	<input type="radio"/> DRIVER	<input type="radio"/> OTHER (DESCRIBE) (m) (INCHES) _____
11	<input type="radio"/> GEARBOX	<input type="radio"/> EXTENSION CABLE PROTECTION (6.2.3.3)
12	<input type="radio"/> INPUT SHAFT	<input type="radio"/> STANDARD CONDUIT _____
13	<input type="radio"/> OUTPUT SHAFT	<input type="radio"/> OPTIONAL WEATHERPROOF FLEXIBLE ARMOR (6.2.3.4)
14	<input type="radio"/> DRIVEN EQUIPMENT	<input type="radio"/> NUMBER OF ACCELEROMETERS PER BEARING _____
15	<input type="radio"/> SPARE TRANSDUCER (6.1.4.2)	<input type="radio"/> NUMBER OF CHANNELS IN TRAIN _____
16	<input type="radio"/> OTHER (DESCRIBE) _____	<b>TEMPERATURE SENSOR DATA (5.3.1)</b>
17	ROD DROP PROBES	<input type="radio"/> SENSORS NOT REQUIRED
18	<input type="radio"/> DUAL PROBES TOP AND BOTTOM	<input type="radio"/> STD GROUNDED, TYPE J IRON/COP.-NICKEL (CONSTANTAN) THERMOCOUPLE
19	<input type="radio"/> TOP ONLY (6.1.3.2)	<input type="radio"/> OPT. 100 OHM, PLATINUM, THREE-LEAD RTD'S, WITH A TEMP. COEFFICIENT
20	<input type="radio"/> BOTTOM ONLY	OF RESISTANCE EQUAL TO 0.00385 OHM/OHM/°C _____
21	<input type="radio"/> OTHER (6.1.3.6) _____	<input type="radio"/> OTHER (DESCRIBE) _____
22	SPEED INDICATOR PROBES (6.1.5.1)	<input type="radio"/> FLEXIBLE STAINLESS STEEL OVERBRAIDING ON LEADS (5.3.1.2)
23	<input type="radio"/> STANDARD	_____
24	<input type="radio"/> OTHER _____	<b>TEMPERATURE SENSOR MOUNTING</b>
25	OVERSPEED SENSING PROBES (6.1.6)	<input type="radio"/> EMBEDDED SENSORS
26	<input type="radio"/> STANDARD	<input type="radio"/> SPRING-LOADED SENSORS (BAYONET TYPE) (6.2.4.3)
27	<input type="radio"/> STANDARD OPTION	<input type="radio"/> OTHER (DESCRIBE) _____
28	<input type="radio"/> OTHER _____	<input type="radio"/> ELECTRICALLY INSULATED FROM BEARING (6.2.4.5)
29	<b>OSCILLATOR-DEMODULATOR</b>	_____
30	<input type="radio"/> SUPPLIED WITH DIN RAIL MOUNTING (5.1.4.2)	<b>RADIAL BEARING TEMPERATURE SENSOR ARRANGEMENT</b>
31	<input type="radio"/> OTHER (SPECIFY) _____	<input type="radio"/> SENSORS REQUIRED
32	_____	<input type="radio"/> SENSORS NOT REQUIRED
33	<b>EXTENSION CABLE DATA (5.1.2)</b>	<input type="checkbox"/> SLEEVE TYPE, L/D RATIO > 0.5 (6.1.8.1.1.a)
34	<input type="radio"/> STANDARD 4.0 METER (160 INCHES) LENGTH, NONARMORED	<input type="checkbox"/> SLEEVE TYPE, L/D RATIO ≤ 0.5 (6.1.8.1.1.b)
35	<input type="radio"/> 4.0 METER (160 INCHES) LENGTH, ARMORED (6.2.1.4)	<input type="checkbox"/> TILT-PAD TYPE, L/D RATIO > 0.5 (6.1.8.1.2.a)
36	<input checked="" type="checkbox"/> CABLE CONNECTOR ELECTRICAL ISOLATION (6.2.1.4)	<input type="checkbox"/> TILT-PAD TYPE, L/D RATIO ≤ 0.5 (6.1.8.1.2.b)
37	<input type="radio"/> INSULATING SLEEVE	<input type="checkbox"/> LOAD-ON PAD (6.1.8.1.2.c)
38	<input type="radio"/> INSULATING WRAP (DESCRIBE) _____	<input type="checkbox"/> LOAD-BETWEEN-PADS (6.1.8.1.2.d)
39	_____	<input type="checkbox"/> OTHER (DESCRIBE) _____
40	<input type="radio"/> OTHER (DESCRIBE) _____	_____
41	_____	_____
42	<b>PIEZO ELECTRIC ACCELEROMETER DATA (5.5)</b>	<b>THRUST BEARING TEMPERATURE SENSOR ARRANGEMENT</b>
43	GENERAL:	<input type="radio"/> SENSORS REQUIRED
44	<input checked="" type="checkbox"/> INSTRUMENT MANUFACTURER'S MODEL NO. _____	<input type="radio"/> SENSORS NOT REQUIRED
45	<input checked="" type="checkbox"/> ACCELEROMETER POWER REQ. _____ 24VDC _____ (mA)	<input type="radio"/> STANDARD TWO SENSORS IN ACTIVE BEARING
46	<input type="checkbox"/> SPECIAL BODY MATERIAL _____	<input type="radio"/> SENSORS _____ DEGREES APART
47	<input type="radio"/> MOUNTING ENVIRONMENT TEMPERATURE °C OR °F _____	<input type="radio"/> STANDARD TWO SENSORS IN INACTIVE BEARING
48	TRANSDUCER MOUNTING:	SENSORS _____ DEGREES APART
49	<input type="radio"/> API APPENDIX FIGURE:      C1      C2      C3	<input type="radio"/> OTHER (DESCRIBE) _____
50	<input type="radio"/> OTHER _____	_____
51	<input type="radio"/> STANDARD MOUNTING/STANDARD ACCELEROMETER (5.2.1.1.3)	_____
52	_____	_____
53	_____	_____

MACHINERY PROTECTION SYSTEM DATA SHEET

JOB NO. PURCH. ORDER NO. INQUIRY NO. REVISION NO. PAGE OF ITEM NO. DATE BY DATE

MONITOR SYSTEM MONITOR MOUNTING DIMENSION (mm) (INCHES) HEIGHT WIDTH DEPTH LOCATION INDOOR OUTDOOR REQUIREMENTS OF SAFETY INSTRUMENTED SYSTEM (SIS) APPLY AS SPECIFIED BELOW REMOTE TIMESET POWER SUPPLY REQUIREMENTS STANDARD OTHER (SPECIFY) ACCURACY REQUIREMENTS FOR STANDARD OPTION POWER SUPPLIES IN ACCORDANCE WITH 5.4.1.7a REDUNDANT POWER SUPPLY REQUIRED OUTPUTS 4 TO 20 mA ANALOG STANDARD DIGITAL OUTPUT GRAPHIC OTHER (DESCRIBE) TAMPERPROOF SHUTDOWN DISARM W/LIGHT EMIT. DIODE CONNECTORS OTHER THAN BNC RELAYS ALARM (ALERT) STANDARD NORMALLY ENERGIZED OPTIONAL NORMALLY DEENERGIZED SHUTDOWN (DANGER) STANDARD NORMALLY DEENERGIZED OPTIONAL NORMALLY ENERGIZED HERMETICALLY SEALED ELECTRO-MECHANICAL TYPE RELAYS CONTACTS RATED AT A RESISTIVE LOAD OF 5 AMPERES AT 120 VOLTS AC RADIAL SHAFT VIBRATION AND AXIAL POSITION CHANNEL (5.4.2 & 5.4.3) TYPE OF DISPLAY NUMBER OF PROBES MONITORED ANALOG RADIAL LIQUID CRYSTAL DIODES LIGHT EMITTING DIODES OTHER (DESCRIBE) REDUNDANT CIRCUIT REQUIREMENT READOUT RANGE RADIAL DISPLAY AXIAL DISPLAY STANDARD 0 TO 125 MICROMETERS -1.0 TO +1.0 mm STANDARD 0 TO 5 MILS -40 TO +40 MILS OPTIONAL 0 TO 250 MICROMETERS OTHER (DESCRIBE) OPTIONAL 0 TO 10 MILS CONTROLLED ACCESS FUNCTION FOR NOTIFICATION OF ALARM AND DANGER SETPOINT MULTIPLIER APPLICATION REQUIRED STANDARD 3X STANDARD OPTION 2X OTHER (DESCRIBE) RADIAL SHAFT VIBRATION AND AXIAL POSITION CHANNEL (CON'T) SHUTDOWN SYSTEM (5.4.2.4) STANDARD DUAL VOTING LOGIC SINGLE CHANNEL SHUTDOWN BYPASS EACH CHANNEL ADDITIONAL DISPLAY AND/OR DIGITAL OUTPUTS (5.4.1.10) CHANNEL ALARM STATUS DISPLAY OUTPUT ARMED/DISARMED SHUTDOWN STATUS ALL MACHINES ALARM STORAGE FOR STORING THE TIME, DATE, AND VALUE FOR A MINIMUM OF 64 ALARMS CHANNEL VALUE ±0.5% FULL-SCALE RANGE RESOLUTION MEASURED VALUE AS A % OF ALARM (ALERT) AND SHUTDOWN (DANGER) VALUES TO 1% RESOLUTION TRANSDUCER OK LIMITS HARDWARE AND SOFTWARE DIAGNOSTICS COMMUNICATIONS LINK STATUS ALARM SETPOINTS GAP VOLTAGE TIME STAMP AND DATE ALL TRANSMITTED DATA LOG OF SYSTEM ENTRY TO INCLUDE DATE, TIME, INDIVIDUAL ACCESS CODE AND RECORD OF CHANGES SETPOINT MULTIPLIER INVOKED OTHER (DESCRIBE) PISTON ROD DROP CHANNELS PISTON ROD DROP MONITORING REQUIRED STANDARD MONITOR SYSTEM SUPPLIED WITH ONE CHANNEL PER PISTON ROD STANDARD OPTION—TWO CHANNELS PER PISTON ROD CASING VIBRATION CHANNEL (5.4.5) CASING VIBRATION NOT REQUIRED CASING VIBRATION REQUIRED NUMBER OF ACCELEROMETERS MONITORED STANDARD MONITOR PUMP, FAN, OR MOTOR WITH ROLLING ELEMENT BEARINGS FREQUENCY RANGE OPTIONS MONITOR AND DISPLAY OF SINGLE CHANNEL ACCELERATION VELOCITY MONITOR AND DISPLAY TWO CHANNELS IN EITHER ACCELERATION VELOCITY MONITOR AND DISPLAY ALTERNATE FILTER OR FREQ. RANGE SPECIFY MONITOR AND DISPLAY UNFILTERED OVERALL VIBRATION MONITOR AND DISPLAY AMPLITUDE IN RMS MONITOR AND DISPLAY TRUE PEAK ALTERNATE SCALE RANGE SPECIFY DUAL VOTING LOGIC

**MACHINERY PROTECTION  
SYSTEM  
DATA SHEET**

JOB NO. \_\_\_\_\_ PAGE \_\_\_\_\_ OF \_\_\_\_\_  
 PURCH. ORDER NO. \_\_\_\_\_ ITEM NO. \_\_\_\_\_  
 INQUIRY NO. \_\_\_\_\_ DATE \_\_\_\_\_  
 REVISION NO. \_\_\_\_\_ BY \_\_\_\_\_  
 DATE \_\_\_\_\_

1	<b>CASING VIBRATION CHANNEL (CON'T)</b>	<b>SYSTEM WIRING &amp; CONDUIT (CON'T)</b>
2	<input type="radio"/> CONTROLLED ACCESS FUNCTION FOR NOTIFICATION OF ALARM AND	OSCILLATOR-DEMOMULAR MOUNTING BOXES
3	DANGER SETPOINT MULTIPLIER APPLICATION REQUIRED (5.4.5.4)	<input type="radio"/> ONE PER MACHINE CASE
4	<input type="radio"/> STANDARD 3X MULTIPLIER	<input type="radio"/> TWO PER MACHINE CASE
5	<input type="radio"/> STANDARD OPTION 2X MULTIPLIER	<input type="radio"/> OTHER (DESCRIBE) _____
6	OTHER (DESCRIBE) _____	
7	_____	
8	_____	
9	<b>BEARING TEMPERATURE CHANNEL (5.4.6)</b>	<b>FIELD-INSTALLED INSTRUMENTS (5.7)</b>
10	MONITOR CONFIGURATION	LOCATION <input type="radio"/> INDOOR <input type="radio"/> OUTDOOR
11	<input type="radio"/> TOTAL NUMBER OF SENSORS MONITORED _____	HOUSING/MOUNTING BOX
12	NUMBER OF BEARINGS MONITORED	<input type="radio"/> NEMA TYPE _____
13	<input type="radio"/> RADIAL _____	DRY AIR PURGE REQUIREMENTS (5.7.2)
14	<input type="radio"/> ACTIVE THRUST _____	<input type="radio"/> NONE REQUIRED
15	<input type="radio"/> INACTIVE THRUST _____	<input type="radio"/> REQUIRED PER ISA-512.4 & NFPA 496
16	<input type="radio"/> OTHER (DESCRIBE) _____	<input type="checkbox"/> TYPE X
17	_____	<input type="checkbox"/> TYPE Y
18	TYPE OF DISPLAY	<b>VENDOR'S DATA (8.3.5.4)</b>
19	<input type="radio"/> STANDARD DIGITAL	<input type="radio"/> NO. OF COPIES OF REQUIRED DOCUMENT _____
20	<input type="radio"/> LIQUID CRYSTAL DIODES	<input type="radio"/> REQUIRED BY (SPECIFY DATE) _____
21	<input type="radio"/> LIGHT EMITTING DIODES	<input type="radio"/> NO. OF PRINTS AND/OR REPRODUCIBLES REQUIRED _____
22	<input type="radio"/> OTHER _____	<input type="radio"/> REQUIRED BY (SPECIFY DATE) _____
23	<input type="radio"/> OTHER _____	<input type="radio"/> OTHER (DESCRIBE) _____
24	READOUT RANGE (5.4.6.1)	_____
25	<input type="radio"/> STANDARD 0°C TO+150°C	_____
26	<input type="radio"/> OPTION 0°F TO +300°F	_____
27	<input type="radio"/> OTHER (DESCRIBE) _____	_____
28	SHUTDOWN SYSTEM	<b>TESTING INSPECTION AND PREP FOR SHIPMENT (7.1.4)</b>
29	<input type="radio"/> STANDARD DUAL VOTING LOGIC	<input type="radio"/> FIELD TESTING PER APPENDIX F
30	<input type="radio"/> EACH RADIAL BEARING	<input type="radio"/> INSPECTION REQUIRED OF MONITORING SYSTEM IN INSTRUMENT
31	<input type="radio"/> ACTIVE THRUST BEARINGS	MANUFACTURERS FACILITY (7.3.2.1.1)
32	<input type="radio"/> INACTIVE THRUST BEARINGS	<input type="radio"/> 10 DAY NOTICE REQUIRED BEFORE TEST
33	<input type="radio"/> OTHER (DESCRIBE) _____	<input type="radio"/> MONITORING SYSTEM TO BE USED DURING MECHANICAL RUNNING TEST
34	_____	(DESCRIBE EXTENT TO BE USED)
35	<input type="radio"/> SINGLE CHANNEL	_____
36	<b>TACHOMETER (5.4.7)</b>	_____
37	<input type="radio"/> TACHOMETER NOT REQUIRED	<input type="radio"/> PROBES CALIBRATED TO INSTALLED PROBE TARGET AREA (7.6.2.1)
38	<input type="radio"/> TACHOMETER REQUIRED	
39	<input type="radio"/> ABILITY TO RECORD/STORE HIGHEST SPEED (5.4.7.1)	<b>MISCELLANEOUS</b>
40	<input type="radio"/> CONTROLLED ACCESS RESET REQUIRED (5.4.7.2)	SPECIAL PACKING, SEALING, MARKING OR STORAGE REQUIREMENTS:
41	<b>SYSTEM WIRING &amp; CONDUIT (5.5)</b>	DESCRIBE (7.4.5):
42	VIBRATION & POSITION SIGNAL CABLE	_____
43	<input type="radio"/> SINGLE CIRCUIT CABLE (APPENDIX D.2)	_____
44	<input type="radio"/> MULTIPLE-CIRCUIT CABLE (APPENDIX D.3)	_____
45	TEMPERATURE SIGNAL CABLE	_____
46	<input type="radio"/> SINGLE CIRCUIT THERMOCOUPLE (APPENDIX D.4)	_____
47	<input type="radio"/> OTHER (DESCRIBE) _____	_____
48	_____	_____
49	_____	_____
50	_____	_____
51	_____	_____
52	_____	_____
53	_____	_____

### SPEED SENSOR DATA SHEET

JOB NO. \_\_\_\_\_ PAGE \_\_\_\_\_ OF \_\_\_\_\_  
 PURCH. ORDER NO. \_\_\_\_\_ ITEM NO. \_\_\_\_\_  
 INQUIRY NO. \_\_\_\_\_ DATE \_\_\_\_\_  
 REVISION NO. \_\_\_\_\_ BY \_\_\_\_\_  
 DATE \_\_\_\_\_

1	<input type="radio"/> ELECTRONIC OVERSPEED DETECTION SYSTEM REQUIRED (5.4.8.1)
2	<input type="radio"/> OVERSPEED DETECTION SHALL BE PART OF A SAFETY INSTRUMENTED SYSTEM (5.4.1.3b)
3	<b>CUSTOMER PROFILE</b>
4	
5	<input type="radio"/> MACHINERY VENDOR
6	<input type="radio"/> OWNER
7	<input type="radio"/> OTHER _____
8	
9	<input type="radio"/> SYSTEM INTEGRATION PERFORMED BY _____
10	
11	
12	
13	
14	<b>MACHINE DETAILS</b>
15	<input type="radio"/> DRIVER
16	<input type="radio"/> STEAM TURBINE
17	<input type="radio"/> GAS TURBINE
18	<input type="radio"/> TURBO EXPANDER
19	<input type="radio"/> OTHER _____
20	
21	<input type="radio"/> MANUFACTURER _____
22	<input type="radio"/> MODEL NO. _____
23	<input type="radio"/> POWER _____
24	<input type="radio"/> RATED SPEED _____
25	<input type="radio"/> OVERSPEED TRIP SPEED _____
26	<input type="radio"/> FASTEST TIME IN WHICH MACHINE SPEED CAN DOUBLE DURING
27	START UP _____
28	
29	<input type="radio"/> DRIVEN MACHINE
30	<input type="radio"/> COMPRESSOR
31	<input type="radio"/> PUMP
32	<input type="radio"/> GENERATOR
33	<input type="radio"/> OTHER _____
34	
35	<input type="radio"/> MANUFACTURER _____
36	<input type="radio"/> MODEL NO. _____
37	<input type="radio"/> POWER _____
38	<input type="radio"/> RATED SPEED _____
39	
40	
41	
42	
43	
44	
45	
46	
47	
48	
49	
50	
51	
52	
53	

**SPEED SENSORS**

SPEED SENSOR TYPE:

PASSIVE MAGNETIC<sup>1</sup>

ACTIVE MAGNETIC<sup>1</sup>

PROXIMITY PROBE

TIP OR POLE PIECE DIAMETER \_\_\_\_\_

LINEAR RANGE  
(PROXIMITY PROBE ONLY) \_\_\_\_\_

MANUFACTURER \_\_\_\_\_

MODEL NO. \_\_\_\_\_

ARE THESE SPEED SENSORS SHARED WITH THE GOVERNOR?

YES<sup>2</sup>

NO

PAGE \_\_\_\_\_ OF \_\_\_\_\_

**SPEED SENSOR  
DATA SHEET**

JOB NO. \_\_\_\_\_ ITEM NO. \_\_\_\_\_  
 PURCH. ORDER NO. \_\_\_\_\_ DATE \_\_\_\_\_  
 INQUIRY NO. \_\_\_\_\_ BY \_\_\_\_\_  
 REVISION NO. \_\_\_\_\_ DATE \_\_\_\_\_

1	<b>SPEED SENSING SURFACE</b>	<b>SUPPLEMENTAL PROXIMITY PROBE INFORMATION</b>
2		
3	<input type="radio"/> LOCATION:	<input type="radio"/> MAXIMUM PEAK-TO-PEAK RADIAL VIBRATION OF SPEED SENSING SURFACE _____
4		
5	<input type="radio"/> DRIVER SIDE OF COUPLING	<input type="radio"/> MAXIMUM VARIATION IN TOOTH DEPTH (DIMENSION B) _____
6	<input type="radio"/> OTHER <sup>3</sup> _____	<input type="radio"/> MAXIMUM RUNOUT OF SPEED SENSING SURFACE DUE TO NON-CONCENTRICITY _____
7		
8	<input type="radio"/> DESIGN:	<input type="radio"/> SIGNAL CABLE LENGTH BETWEEN OSCILLATOR/DEMODULATOR AND MONITOR _____
9		
10	<input type="radio"/> NON-PRECISION OR GEAR <sup>4</sup> (SEE FIGURE J-3)	<input type="radio"/> PEAK-TO-PEAK OUTPUT VOLTAGE OF TRANSDUCER VIEWING SPEED SENSING SURFACE _____
11	<input type="radio"/> PRECISION (SEE FIGURE J-4)	
12		
13	<input type="radio"/> EVENTS PER REVOLUTION _____	
14		
15	<input type="radio"/> DIMENSIONS (SEE FIGURE J-2):	<b>SUPPLEMENTAL MAGNETIC SPEED SENSOR INFORMATION</b>
16		
17	<input type="radio"/> TOOTH LENGTH A = _____	<input type="radio"/> MINIMUM RPM TO BE SENSED _____
18	<input type="radio"/> TOOTH DEPTH B = _____	<input type="radio"/> SURFACE SPEED OF SPEED SENSING SURFACE AT THIS MINIMUM RPM _____
19	<input type="radio"/> NOTCH LENGTH C = _____	<input type="radio"/> PEAK-TO-PEAK VOLTAGE OUTPUT AT MINIMUM RPM _____
20	<input type="radio"/> TOOTH WIDTH F = _____	<input type="radio"/> MAXIMUM SURFACE SPEED AT MAXIMUM (TRIP) RPM _____
21		<input type="radio"/> PEAK-TO-PEAK VOLTAGE OUTPUT AT MAXIMUM (TRIP) RPM _____
22	<input type="radio"/> ARE ANY DIMENSIONS ABOVE SMALLER THAN ALLOWED IN TABLES J-2 OR J-3 (AS APPLICABLE):	<input type="radio"/> POLE PIECE TYPE:
23		<input type="radio"/> CYLINDRICAL
24	<input type="radio"/> YES <sup>5</sup>	<input type="radio"/> CONICAL
25	<input type="radio"/> NO	<input type="radio"/> CHISEL
26		<input type="radio"/> POLE PIECE DIAMETER _____
27	<input type="radio"/> IS CENTERLINE OF SPEED SENSING SURFACE SUBJECT TO PEAK-TO-PEAK RADIAL VIBRATION AMPLITUDES GREATER THAN B/4 (1/4 TOOTH DEPTH):	<input type="radio"/> GEAR OR TOOTH PITCH _____
28		<input type="radio"/> GEAR OR WHEEL DIAMETER _____
29	<input type="radio"/> YES <sup>5</sup>	
30	<input type="radio"/> NO	
31	<input type="radio"/> IS THE FOLLOWING RELATIONSHIP TRUE:	
32		
33	$\frac{(Events / rev) \times (Trip Speed) \times (A + C)}{A \text{ or } C \text{ (whichever is greater)}} > 720,000 \text{ RPM}$	
34		
35	<input type="radio"/> YES <sup>5</sup>	
36	<input type="radio"/> NO	
37		
38		
39		
40		
41		
42		
43		
44		
45		

Notes:

1. When magnetic speed sensors are used, the section of the data sheet titled "SUPPLEMENTAL MAGNETIC SPEED SENSOR INFORMATION" should be completed.
2. Transducers shared between the overspeed detection system and the governor are not permitted under this standard (see Section 5.4.8.4k).
3. Since a coupling failure and consequent instantaneous loss of load is a common cause of driver overspeed, this standard does not permit speed sensing of the driven shaft for overspeed applications (see Section 6.1.6.4).
4. A speed sensing surface used as a gear for driving other mechanical components is not permitted under this standard (see Section 6.1.6.4).
5. A "yes" response requires additional information to be supplied to the machinery protection system vendor to ensure the proposed speed sensing surface is compatible with the speed sensors and monitor. The section of the data sheet titled "SUPPLEMENTAL PROXIMITY PROBE INFORMATION" should be completed and reviewed with the machinery protection system vendor.

## APPENDIX B—TYPICAL RESPONSIBILITY MATRIX WORKSHEET<sup>a</sup>

JOB NO. \_\_\_\_\_ ITEM NO. \_\_\_\_\_

PURCHASE ORDER NO. \_\_\_\_\_ DATE \_\_\_\_\_

REQUISITION NO. \_\_\_\_\_ DATE \_\_\_\_\_

INQUIRY NO. \_\_\_\_\_ DATE \_\_\_\_\_

PAGE \_\_\_\_\_ OF \_\_\_\_\_ BY \_\_\_\_\_

FOR \_\_\_\_\_ REVISION \_\_\_\_\_

SITE \_\_\_\_\_ UNIT \_\_\_\_\_

SERVICE \_\_\_\_\_ NO. REQUIRED \_\_\_\_\_

FUNCTION	MACHINERY PROTECTION SYSTEM VENDOR	MACHINERY VENDOR <sup>b</sup>	CONSTRUCTION AGENCY	OWNER	OTHER (SPECIFY: _____)
Project coordination (see 8.1.3)					
System design					
Instrument purchase					
Panel design and assembly					
Grounding plan (see 5.6.1)					
Supply of drawing and data per Appendix G					
Installation on machinery train					
Mechanical running test with contract instrumentation (see 7.5)					
Factory acceptance test (see 7.3.2.1.1)					
System integration verification <sup>c</sup>					
Field test (see 7.6)					

**Discussion:**

- a. The purpose of this form is to assist in project coordination. It should be completed by the purchaser by placing an “X” in the appropriate boxes to indicate responsibility for each function (see 4.7).
- b. Responsibility would normally be placed with the prime machinery vendor having unit responsibility for the entire machinery train. If responsibilities are divided among individual machinery vendors, appropriate statements should be noted above or on an attached sheet.
- c. This pertains to the digital output options (see 5.4.1.4.e and 5.4.1.10) that may be integral to the machinery control system. This task is normally the responsibility of the construction agency.





## APPENDIX C—ACCELEROMETER APPLICATION CONSIDERATIONS

### C.1 General

**C.1.1** The accelerometer is a contact sensor (as opposed to a non-contact proximity probe) that measures the motion of the surface to which it is attached. Its many benefits include linearity over a wide frequency and dynamic range. Accelerometers have typically been used in higher frequency applications (over 1 kHz) for machinery monitoring and diagnostics. In order to apply the accelerometer and get reliable measurements, proper attention must be paid to the following areas:

- a. Sensor mounting configurations.
- b. Frequency range of interest.
- c. Amplitude range of interest.
- d. Use for machine protection or for diagnostics.
- e. Characteristics of the particular accelerometer under consideration.
- f. Cabling and signal conditioning.
- g. Environmental considerations.

**C.1.2** There are many good reference sources discussing these considerations. The manufacturer of the particular accelerometer can also be consulted for answers to application questions. The primary focus of this appendix is to address sensor mounting, cabling, and signal conditioning considerations for use with machine protection systems. Typically, accelerometers are recommended for use up to about one-third to one-half of their mounted resonant frequency. Therefore, mounting techniques can limit the useful frequency range of the accelerometer. Knowing these limitations and applying the proper technique are necessary to meet the requirements of the monitoring application. Cabling and signal conditioning can affect the accelerometer output signal and therefore are also important considerations in the overall design of the measurement system.

### C.2 Accelerometer Mounts and Mounting Considerations

Since the accelerometer is a contact device, care in mounting is of particular importance because improper installation can affect the performance of the device and give unreliable and unexpected output signals.

#### C.2.1 FLUSH-MOUNTING

Figure C-1 shows a typical flush-mounting application allowing the accelerometer base to fully contact the mounting surface. This mounting technique is necessary for applications where frequencies above 2 kHz must be monitored such as gear mesh frequencies on gearboxes, blade or vane passing frequencies on pumps and compressors, and rolling element bearing frequencies for predictive maintenance diagnostics.

The following are offered as guidelines for proper flush-mounting:

- a. Requirements for the surface finish, flatness, and size of the mounting surface are as shown in Figure C-1.
- b. The accelerometer must seat itself to the mounting surface over its entire base to prevent mounting-post resonance. Mounting-post resonance occurs when the accelerometer base is not flush against the mounting surface and the mounting stud becomes a structural element, lowering the mounted resonance frequency. To prevent this from occurring, the stud axis must be perpendicular to the mounting surface and the tapped hole must be deep enough to prevent the stud from bottoming. The mounting hole must be perpendicular to the surface within 5 degrees of arc or less.
- c. Excessive mounting torque might distort the accelerometer case, thus affecting the accelerometer response characteristics. Too little torque will result in a loose accelerometer that can lead to large errors at higher frequencies. Torque requirements vary with stud size, but published values range from 0.6 to 2.7 newton-meters (5 to 24 pound-inches). Manufacturer recommendations should be followed.
- d. The mounting interface should be clear of any particles or debris that could prevent the accelerometer from coming down flat on the mounting surface. A thin layer of silicone grease may be applied between the accelerometer and the mounting surface to fill minute voids and improve the stiffness of the mounting.

#### C.2.2 NON-FLUSH-MOUNTING

**C.2.2.1** Figure C-2 shows a non-flush-mounted accelerometer application. This mounting configuration uses tapered pipe threads. The advantage of this type of mounting configuration is that it only requires a drilled and tapped hole to be made at the measurement location for proper mounting. The accelerometer is already built onto the stud and sealed in its case. However, this type of accelerometer mount is not appropriate for applications where frequencies above 2 kHz must be monitored. This design is often used for solid-state velocity transducers (accelerometers with a built-in acceleration-to-velocity integrator).

**C.2.2.2** The following should be considered when using this type of accelerometer configuration for monitoring:

- a. The machine point at which the accelerometer is to be mounted should be massive enough to accommodate the mass of the accelerometer without altering the response of the structure. The machines considered for permanent monitoring in this specification will typically be suitable for this method of mounting.

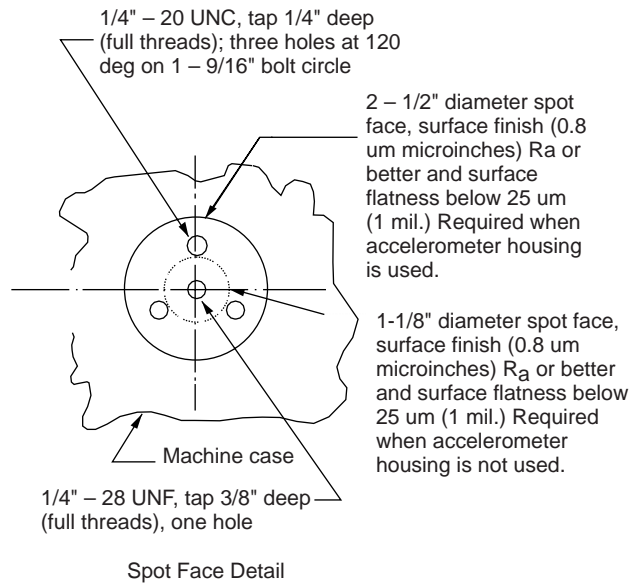
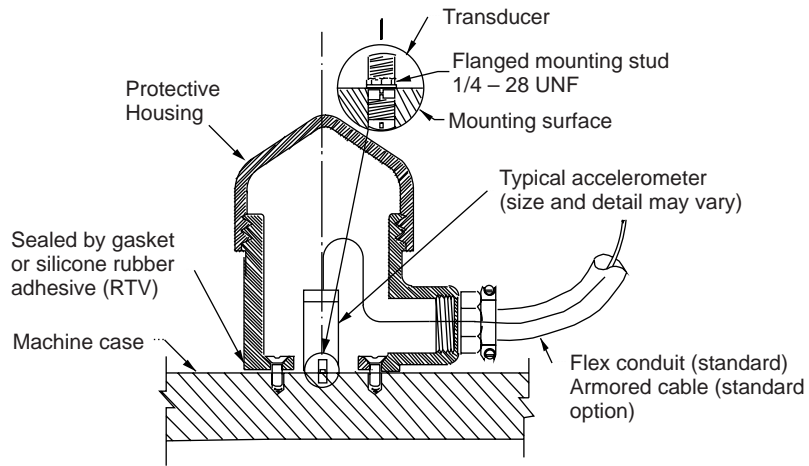

Note:

1. Spot face is shown but a raised boss with proper surface finish is acceptable.

Figure C-1—Typical Flush Mounted Accelerometer Details

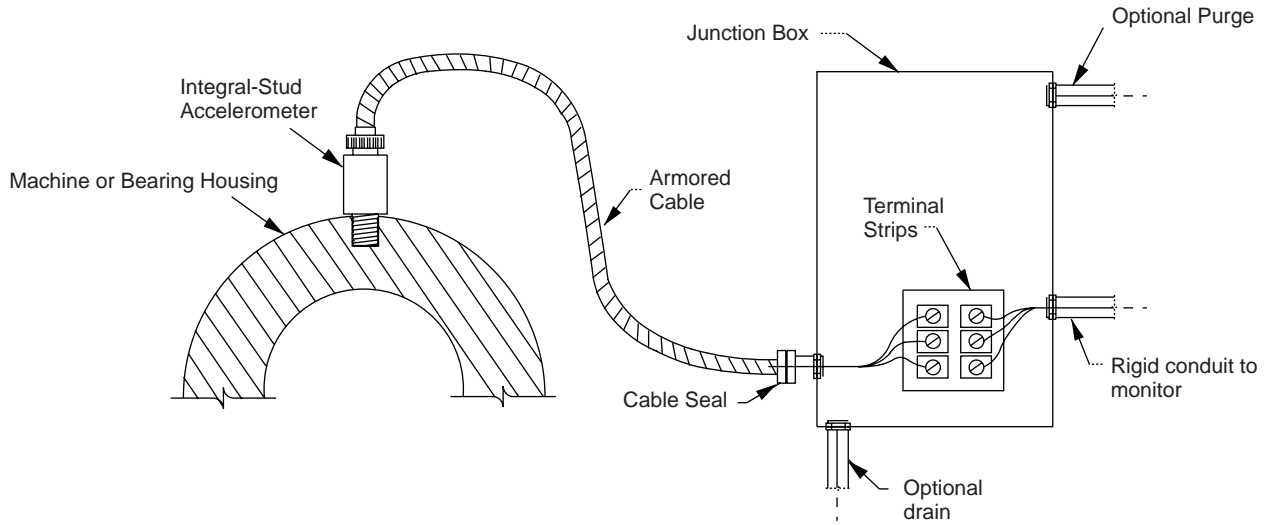

Figure C-2—Typical Non-Flush Mounted Arrangement Details for Integral-Stud Accelerometer

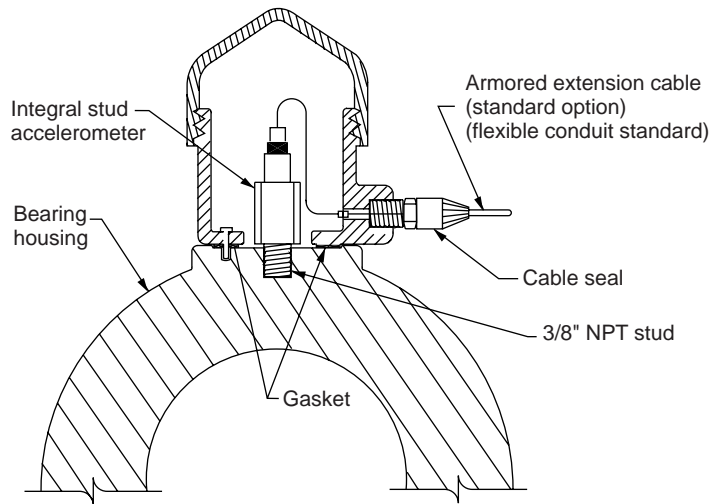

Figure C-3—Typical Non-Flush Mounting Arrangement for Integral-Stud Accelerometer and Armored Extension Cable

- b. The drilled and tapped mounting hole should be perpendicular to the measurement surface within 5 degrees of arc or less.
- c. The manufacturer's torque specifications should be followed to avoid damaging the case by over-tightening or affecting the frequency response through looseness. A thread-locking compound may be used.

### **C.2.3 USE OF ADHESIVES AND BONDING AGENTS**

The use of bonding agents (such as bee's wax, dental cement, epoxy cement, and methyl cyanoacrylate cement) for mounting is not discussed here because these agents are not considered suitable for permanent installations.

### **C.2.4 ACCELEROMETER HOUSINGS VERSUS UNPROTECTED MOUNTING**

A common method of protecting the accelerometer and its connector is to mount it within a housing. Installation kits available from various sources consist of a modified electric junction box or explosion-proof housing. The housing must be separated from the accelerometer (to prevent affecting the accelerometer's frequency response), normally by cutting a hole in the bottom of the box or housing (see note). Installation requires care to prevent contact between the accelerometer case and its housing. The housing cover must allow room for the proper cable bend radius, particularly important when top-mounted cable connectors are used. The box must also be mounted on a relatively wide and flat surface to permit proper sealing of the base and to prevent water intrusion. See Figure C-1 for an example of an accelerometer housing.

Note: Cutting the bottom of an explosion-proof box renders it non-explosion-proof. Other means must be used to meet area classification requirements.

## **C.3 Installation and Protection of Cables**

Mechanical protection of the cable can be achieved by running the cable in rigid conduit. However, maintenance requirements dictate easy removal and reinstallation of the conduit section closest to the machinery. The use of flexible conduit is not necessarily the best solution because it is not easy to remove, does not always stay in place, and often results in cable damage caused by the sharp edges of the internal reinforcing coil. Consider using armored cables as shown in Figure C-3. This type of cable is relatively flexible and can be routed next to the machinery below guards or flanges. If properly routed and securely clamped, it cannot be used as a footstep. Unlike applications using conduit, installation or removal of this type of cable does not require an electrician. The following precautions apply:

- a. If the accelerometer is left unprotected, water intrusion in the connector can be alleviated by filling the connector with a silicon grease. A commercially available silicon sealing compound or a specially designed protective boot can be used to seal the connector entry to the accelerometer.
- b. The conduit or junction box must be sealed at the cable entry point. Rubber grommets or removable, non-adhesive sealants should be used.
- c. The cable must be routed to avoid excessive temperatures. Cable material limits must be considered. As an example, PTFE-insulated cables cannot normally be used above 200°C (400°F).
- d. Where the hazardous area classification requires it, consideration should be given to the use of barriers of the zener type located as close as possible to the power source in a safe area. Intrinsically safe installations can be achieved by using this type of energy-limiting device. However, the machinery protection system vendor should be consulted for overall system design considerations.
- e. Avoid running the cable near sources of electromagnetic interference (EMI) such as large motors or high-voltage wiring.

## APPENDIX D—SIGNAL CABLE

### D.1 General

This appendix covers the minimum requirements for single- and multiple-circuit signal cable for vibration, axial position, speed sensing, and RTD transducers and single- and multiple-circuit signal cable for thermocouples. All of these cables require mechanical support and protection such as by cable armor, conduit, tray system, or combination thereof. The insulation shall conform to Article 725 of NFPA 70 (*National Electrical Code*), Class 2P, and shall withstand, with no shorts, a 1-minute test potential of 1000 volts DC plus two times the rated voltage between conductor-to-conductor and conductor-to-shield. More detailed information on signal transmission systems is available in API Recommended Practice 552.

### D.2 Shielded Single-Circuit Signal Cable for Vibration, Axial Position, Speed Sensing, or RTD Transducers

#### D.2.1 CONDUCTORS

Shielded single-circuit cable for vibration, axial position, and speed sensing transducers shall contain three twisted conductors. The conductors shall be 16 to 22 American Wire Gage (AWG), or 0.336 to 1.374 square millimeters, seven-strand (minimum), Class B, concentric-lay, tinned copper wire as specified in NEMA WC 5, Part 2 (IPCEA S-61-402). The lay of the conductor's twist shall be from 38 to 64 millimeters (1.5 to 2.5 in.). The conductors shall be color coded black, white, and red. The drain wire attached to the cable shield shall have the same specification as the three twisted conductors. Prior to installation of the cable, a green or green and yellow stripe sleeving shall be installed over the drain wire.

#### ● D.2.2 PRIMARY INSULATION

The conductors' primary insulation shall be rated for 300 volts, 100°C (200°F) and pass the Underwriters' Laboratories (UL) VW-1 flame test. The standard primary insulation shall be polyvinyl-chloride (PVC) with a thickness of 0.38 millimeter (15 mils). When specified, fluorinated ethylene propylene (FEP) with a thickness of 0.25 millimeter (10 mils) will be the standard option for severe environment use.

#### D.2.3 SHIELD

The cable shield shall be polyester/aluminum film tape with 100% coverage and drain wire, or tinned copper wire braid with 90% coverage. The tape shall be helically applied with a minimum of a 25% overlap. The aluminum-coated side of the film shall be at least 0.9 micrometer (0.35 mil)

thick and shall be in continuous contact with the drain wire, which shall be the same wire gage as the inner conductors of the cable and meet the other requirements of D.2.1. A braided shield shall have a single conductor attached to it. The single conductor shall be the same wire gage as in the inner conductors of the cable and meet the other requirements of D.2.1.

#### ● D.2.4 OVERALL JACKET

The cable's standard jacket shall be PVC with a nominal thickness of 0.75 millimeter (30 mils) and meet the other requirements of D.2.2. When specified, FEP with a thickness of 0.25 millimeter (10 mils) will be the standard option for severe environment use.

### D.3 Multiple-Circuit Signal Cable (with Group Shields) for Vibration, Axial Position, Speed Sensing, or RTD Transducers

#### D.3.1 CONDUCTORS

Multiple-circuit cable with group shields is recommended (see note). Multiple-circuit cable with group shields for vibration or axial position transducers shall contain three twisted conductors per group. The conductors shall be 16 to 22 AWG, seven-strand, Class B, concentric-lay, tinned copper wire as specified in NEMA WC 5, Part 2 (IPCEA S-61-402). The lay of the conductors' twist shall be from 38 to 64 millimeters (1.5 to 2.5 in.). The conductors in each group shall be color-coded black, white, and red, and each group of three shall be identifiable by using colors or numbers.

Note: Group shields are recommended to minimize cross-talk between monitoring channels.

#### D.3.2 PRIMARY INSULATION

The conductors' primary insulation shall be the same as stated in D.2.2.

#### D.3.3 OVERALL SHIELD

The shield of each three-conductor group and the overall shield (see note) of the multiple-circuit cable shall be polyester/aluminum-coated film or braided tinned copper. The shield specifications shall be the same as stated in D.2.3.

Note: Overall shields are recommended to provide isolation from external noise.

#### D.3.4 COMMUNICATIONS WIRE

The cable shall contain a 16 to 22 AWG, seven-strand, Class B, concentric-lay, copper communication wire whose

insulation is 1.9 millimeters (75 mils) thick. The communication wire shall be coded with a color other than the group color.

## D.4 Signal Cable for Thermocouples

### D.4.1 CONDUCTORS

Single-circuit signal cable for thermocouples shall consist of a twisted pair of conductors. Single- or multiple-circuit cables are acceptable. The conductors shall be 16 to 22 AWG solid (stranded can be used) wire, matched and calibrated as specified in ANSI MC96.1. The lay of the conductors' twist shall be a maximum of 51 millimeters (2 in.). The conductors shall be color coded as specified in Table D-1.

### D.4.2 PRIMARY INSULATION

The conductors' primary insulation shall be the same as stated in D.2.2.

### D.4.3 SHIELD

The cable shield shall be the same as stated in D.2.3.

### D.4.4 PAIR JACKET

The cable's pair jacket shall have a nominal thickness of 0.9 millimeter (35 mils), be of the color specified in Table D-1, and meet the other requirements stated in D.2.2.

Table D-1—Color Coding for Single-Circuit Thermocouple Signal Cable

Type <sup>a</sup>	Pair Jacket	Conductor	
		Positive	Negative
TX	Blue	Blue	Red
JX	Black	White	Red
EX	Purple	Purple	Red
KX	Yellow	Yellow	Red
SX	Green	Black	Red
BX	Gray	Gray	Red

<sup>a</sup>Type designations are from ANSI MC96.1, Table VI.

## APPENDIX E—GEARBOX CASING VIBRATION CONSIDERATIONS

### E.1 General

The requirements for monitoring casing vibration on a variety of machine types are specified in 5.4.5. This appendix provides additional considerations specific to gearboxes. Paragraph 5.4.5.5.a requires the use of a dual-path monitor for gear casing measurements. It receives its input signal from an accelerometer mounted on a gear bearing housing (API 613 for special purpose gear units directs that one accelerometer be mounted horizontally on the output bearing housing, one accelerometer be mounted horizontally on the input bearing housing, and that they be mounted below the split line unless otherwise specified). This signal is divided into two separate paths in the monitor. The first path is band-pass filtered and read out directly in peak acceleration units (g's or meters per second squared). This path observes the frequencies between 1,000 hertz and 10 kilohertz. These frequencies are associated with gear mesh and provide information on mesh condition. The second path is integrated to rms velocity units (in inches per second or millimeters per second). This signal is band-pass filtered to observe frequencies between 10 Hz and 1,000 Hz. These frequencies are associated with the vibration of the rotating elements. It provides additional machine condition information to supplement a shaft vibration monitor.

### E.2 Signal Detection Schemes

Two signal detection schemes are used simultaneously in the gearbox casing vibration monitor. They are true peak and true rms.

**E.2.1** A true peak detector responds (within certain limitations of the amplifier) to excursions of the signal from zero to a maximum (or minimum). This technique is equally sensitive to both periodic and short duration (low duty cycle) vibration events in the waveform. Because gears tend to generate the short duration (spike) vibration events when malfunctioning, peak detection is the standard for monitoring gear-related activity.

**E.2.2** A true rms detector responds to the total area within the vibration waveform. It is less sensitive to short duration vibration events and tends to average them out as a form of filter. (Details of the actual mathematics of rms detection are available in many texts.)

**E.2.3** While the standard dual-path detection scheme for gearbox casing vibration uses a combination of true peak

and rms measurements, 5.4.5.6 allows the user to optionally specify both paths in either peak or rms units. Use of one technique over the other is usually determined by geographical and historical preferences. Advocates of a peak measurement prefer it because it is easy to understand and it responds to the short duration events described in E.2.1. Advocates of an rms measurement prefer its smoothing effect and the lower values it yields.

**E.2.4** Several important additional factors must also be considered:

a. The detection circuitry in the monitor must be consistent with the displayed units. If peak is displayed, a peak circuit detector must be used in the monitor circuitry. Confusion occurs when an rms detector is used in the monitor and its output is scaled by 1.414 to display as peak units. This conversion is only valid for purely sinusoidal signals, which is rarely the situation except during calibration. An instrument displaying peak as  $1.414 \times \text{rms}$  may yield significantly lower values than one with a true peak detector when observing the same vibration signal. Many portable instruments use this approach, which can create confusion when comparing readings. To avoid confusion, it is recommended that peak measurements derived from rms be referred to as “derived peak” to distinguish them from “true peak” measurements.

b. Use the same units for both acceptance testing and permanent monitoring. This allows direct comparison and reduces confusion.

c. An AC voltmeter is commonly used for instrument calibration. Voltmeter calibration traceability is most common in rms terms. Calibration of a peak detecting instrument using  $\text{rms} \times 1.414$  may be utilized, but is only valid for a pure sine wave signal.

d. Alarm limits must reflect the units used. Use of empirically determined peak limits with an instrument using rms detection may result in machine damage. The reverse may provide unwanted alarms.

Selection of a scheme depends on experience. Companies with a database of machinery measurements and vibration limits in peak terms may not be comfortable using rms, and vice-versa. Each scheme can be made to work by knowledgeable people. Care and understanding must be applied to each application to ensure that adequate machine protection is provided.





## APPENDIX F—FIELD TESTING AND DOCUMENTATION REQUIREMENTS

### F.1 General

**F.1.1** This appendix outlines minimum field testing and documentation requirements for machinery protection system components. It is intended as a convenience to the purchaser and the owner in clearly specifying the total job requirements.

**F.1.2** Verification and documentation shall be submitted to the owner as follows:

- a. Machinery vendors shall submit documentation at least 2 weeks prior to any factory mechanical testing.
- b. Construction agencies shall submit documentation at least 4 weeks prior to machine start-up.

### F.2 Tools and Instrumentation

The codes in Table F-1 are used to designate tools and instruments needed to calibrate and test various portions of the machinery protection system.

### F.3 Vendor Requirements

The purchaser shall use the form in Table F-2 to indicate the required activities and the responsible agency or vendor required to perform each specified activity.

Table F-1—Tools and Instruments Needed to Calibrate and Test Machinery Protection Systems

Code	Tool or Instrument	Typical Application
A	DC voltage nulling instrument	Shaft electrical and mechanical runout testing and documentation
B	Analog X-Y plotter or dual channel storage oscilloscope with digital plotter and required software	Shaft electrical and mechanical runout testing and documentation
C	Proximity probe calibration test kit	System calibration, functional, and accuracy testing
D	Calibrated digital multimeter and frequency measuring device	System calibration, functional, and accuracy testing
E	Variable frequency waveform and pulse generator with DC offset	Simulation testing for vibration, position, tachometer, and overspeed detection channels
F	Variable frequency shaker with calibrated reference accelerometer	Accelerometer testing
G	Oscilloscope	Simulation testing for vibration, position, tachometer, and overspeed detection channels
H	Temperature sensor simulator	Simulation testing for temperature channels

Table F-2—Data, Drawing, and Test Worksheet

## Directions:

- I – Activity item number  
 R – An X in this box indicates a required activity to be performed by the machinery protection system vendor.  
 M – An X in this box indicates a required activity to be performed by the machinery vendor.  
 C – An X in this box indicates a required activity to be performed by the construction agency.  
 O – An X in this box indicates a required activity to be performed by other agency; specify agency.

I	R	M	C	O	Activity	Tool and Instrument Codes <sup>a</sup> (Paragraph Reference)
1					Location of rotor nodal points	(6.1.1.1 Items e and f, Table G-2 Item 6)
2					Electrical/mechanical runout documentation	A, B, C, D (6.1.1.3, 6.1.1.3, 6.1.2.4, Table G-2 Item 5)
3					Calibration curve for each proximity probe transducer	C, D (7.6.2.1, Table G-2 Item 5)
4					Acceleration or velocity shaker test	D, E, F (7.6.2.3, Table G-2 Item 5)
5					System arrangement plan	(Table G-2 Item 4)
6					Monitor system calibration check	C, D, E, F, H (4.5, 7.6.2, Table G-2 Item 19g)
7					Recommended alarm and shutdown setpoints	(Table G-2 Item 7)
7.1					Shaft vibration	(Table G-2 Item 7)
7.2					Shaft axial position	(Table G-2 Item 7)
7.3					Radial bearing temperature	(Table G-2 Item 7)
7.4					Thrust bearing temperature	(Table G-2 Item 7)
7.5					Casing acceleration	(Table G-2 Item 7)
7.6					Casing Velocity	(Table G-2 Item 7)
7.7					Piston Rod Drop	(Table G-2 Item 7)
7.8					Overspeed Detection	(Table G-2 Item 7)
8					Operation for hazardous area compliance testing	(5.7)
9					Channel accuracy test	C, D, E, F, H (Table 1)
9.1					Radial shaft vibration	C, D, E (Table 1, 7.6.2.1)
9.2					Axial position	C, D, E (Table 1, 7.6.2.1)
9.3					Casing Vibration	D, E, F (Table 1, 7.6.2.3)
9.4					Temperature	D, H (Table 1, 7.6.2.2)
9.5					Piston Rod Drop	C, D, E (Table 1, 7.6.2.1)
9.6					Overspeed Detection	D, E (Table 1, 7.6.2.4)
10					Buffered output versus input accuracy	C, D, E, F (Table 1, 5.4.1.4 Item c, 7.6.2)

Table F-2—Data, Drawing, and Test Worksheet (Continued)

## Directions:

- I – Activity item number  
 R – An X in this box indicates a required activity to be performed by the machinery protection system vendor.  
 M – An X in this box indicates a required activity to be performed by the machinery vendor.  
 C – An X in this box indicates a required activity to be performed by the construction agency.  
 O – An X in this box indicates a required activity to be performed by other agency; specify agency.

I	R	M	C	O	Activity	Tool and Instrument Codes <sup>a</sup> (Paragraph Reference)
11					Power supply short-circuit test	D (5.4.1.7 Item d, 7.6.1)
12					Output relay tests	(7.6.1)
12.1					Circuit fault	C, D, E (5.4.1.3 Item a, 5.4.1.8 Item f, 5.4.2.2, 5.4.3.2, 5.4.4.5, 5.4.5.3, 5.4.6.2, 7.6.1)
12.2					Shaft axial position alarm	C, D, E (5.4.1.5 Item a, 5.4.3.3, 7.6.1)
12.3					Shaft axial position shutdown	C, D, E (5.4.1.5 Item a, 5.4.3.3, 5.4.3.4, 7.6.1)
12.4					Radial shaft vibration alarm	C, D, E (5.4.1.5 Item a, 5.4.2.4, 5.4.2.5, 7.6.1)
12.5					Radial shaft vibration shutdown	C, D, E (5.4.1.5 Item a, 5.4.2.4, 5.4.2.5, 7.6.1)
12.6					Casing vibration alarm	D, E, F (5.4.1.5 Item a, 5.4.5.4, 7.6.1)
12.7					Casing vibration shutdown	D, E, F (5.4.1.5 Item a, 5.4.5.4, 7.6.1)
12.8					Temperature alarm	D, H (5.4.1.5 Item a, 7.6.1)
12.9					Temperature shutdown	D, H (5.4.1.5 Item a, 5.4.6.4, 7.6.1)
12.10					Piston Rod Drop alarm	C, D, E (5.4.1.5 Item a, 7.6.1)
12.11					Piston Rod Drop shutdown	C, D, E (5.4.1.5 Item a, 5.4.4.6, 7.6.1)
12.12					Overspeed Detection alarm	D, E, G (5.4.1.8 Item b, 5.4.8.4 Items c and e, 7.6.1)
12.13					Overspeed Detection shutdown	D, E, G (5.4.1.8 Item b, 5.4.8.4 Items d and f, 7.6.1)
13					System shutdown disarm test	C, D, E (5.4.1.9, 7.6.1)
14					Communication interface Functional test	C, D, E, F, G, H (5.4.1.10, 7.6.1)
14.1					Analog 4-20 mA outputs	C, D, E, F, H (5.4.1.4 Item f, 7.6.1)
14.2					Digital communications port	(5.4.1.4 Item e, 5.4.1.10, 7.6.1)
15					First out alarm and shutdown test	C, E, F, H (5.4.1.5 Item j, 7.6.1)
16					Circuit fault functional test	C, D, E (5.4.1.4 Item b, 7.6.1)
17					Shutdown system functional test	E, H (5.4.1.5 Item g, 5.4.1.6 Item b, 7.6.1)

Table F-2—Data, Drawing, and Test Worksheet (Continued)

## Directions:

- I – Activity item number  
 R – An X in this box indicates a required activity to be performed by the machinery protection system vendor.  
 M – An X in this box indicates a required activity to be performed by the machinery vendor.  
 C – An X in this box indicates a required activity to be performed by the construction agency.  
 O – An X in this box indicates a required activity to be performed by other agency; specify agency.

I	R	M	C	O	Activity	Tool and Instrument Codes <sup>a</sup> (Paragraph Reference)
18					Individual channel shutdown disarm test	C, D, E (5.4.1.5 Item h, 7.6.1)
19					Voting logic tests	(7.6.1)
19.1					Shaft axial position	D, E (5.4.3.4, 7.6.1)
19.2					Radial shaft vibration	D, E (5.4.2.4, 7.6.1)
19.3					Casing vibration	D, E (7.6.1)
19.4					Temperature	D, H (5.4.6.4, 7.6.1)
19.5					Piston Rod Drop	D, E (7.6.1)
19.6					Overspeed Detection	D, E (5.4.8.4 Items c, d, e, and f, 7.6.1)
20					Casing vibration filter cutoff frequency	D, E, (5.4.5.2, 7.6.1)
21					Temperature sensor downscale failure verification test	(5.4.6.2, 7.6.1)
22					System wiring signal loss test	D, E, G (7.6.1)
23					Wiring connection verification test	(7.6.1)
24					Radio transmission RFI verification test	(5.7.3)
25					System integration test	C, D, E, F, G (7.6.3)
26					Final system arrangement plan	(8.3.5.2, Table G-2 Item 10)

<sup>a</sup>Tool and instrument codes are listed in Table F-1.

## APPENDIX G—CONTRACT DRAWING AND DATA REQUIREMENTS

Table G-2 is a sample distribution record (schedule). The listed drawing and data types are required, however the manufacturers may use different names for the same drawing. The items in the description column should be modified in the

early stages of the order using the drawing names supplied by the manufacturer.

For purposes of illustration, Table G-1 includes a typical major milestone timeline.

Table G-1—Typical Milestone Timeline

Milestone	Paragraph Reference	Typical Schedule	Activity
T1			Initial specification and request for quotation
T2			Proposal
T3			Contract
T3.1	8.1.3	4 to 6 weeks after T3	Coordination meeting, covering the machinery protection system, involving vendor with unit responsibility, Purchaser and machinery protection system vendor.
A	7.6/Figure 19-20, 8.3.2.1, 8.3.3.1	6 weeks after T3	Purchaser obtains and supplies to Owner: setpoints, parts list & recommended spares, system arrangement plans, system schematics and datasheets.
B		4 weeks prior to T4	Construction agency obtains Channel Tagging requirements from Owner (including content, location, material and method of attachment) and forwards the data to the Machinery protection system vendor.
T4			Machinery protection system vendor shipping date.
A	8.3.5.2, 8.3.5.3	5 days after T4	Machinery protection system vendor supplies standard manuals.
B	6.1.1	Before machining	Purchaser obtains from Machinery vendor and supplies to Owner the location of rotor nodal points.
C	Appendix F	2 weeks prior to T5	Machinery vendor supplies verification and documentation data.
D	Appendix F 7.6/Figure 21 & Table-3A	Before T5	Machinery vendor supplies to Purchaser run-out data and calibration data on each transducer.
T5			Machine shop test date.
T6			Machine shipping date.
A	Appendix F 7.6/Figure 21 & Table-3A	4 weeks prior to T7	Purchaser forwards contract data to Owner.
B	Appendix F 7.6/Figure 21 & Table-3A	4 weeks prior to T7	Purchaser forwards run-out and calibration data on each transducer to Owner.
T7			Functional test
A	8.3.5.4	4 weeks after T7	Construction agency provides Purchaser technical data manual.
B	8.3.4.2	Before T8	Reviewed spare parts list is given to Purchaser with time enough to purchase and receive spares for field start-up.
C	Appendix F	4 weeks prior to T8	Construction agency supplies verification and documentation data.
T8			Field start-up

Note: The above Milestone Timeline Table is typical of projects for which the machinery vendor is unit responsible and hence procures the complete machinery vibration protection system. With the widespread use of distributed control systems in the industry, more and more machinery protection systems are being installed in local equipment rooms and central control rooms, rather than local to the machine train.

For these types of projects, the Engineering contractor often assumes responsibility for all aspects of the machinery protection system supply including: procuring the protection monitor panels, coordinating the transducer supply from the machinery protection system vendor to the Machinery vendor, and coordinating any required third party system integration testing.



<p>Notes:</p> <p>1. Send all drawings and data to _____</p> <p>_____</p> <p>2. All drawings and data must show project, appropriation, purchase order, and item numbers in addition to the plant location and unit. In addition to the copies specified above, one set of the drawings / instructions necessary for field installation must be forwarded with the shipment.</p> <p>Nomenclature:</p> <p>_____ S—number of weeks prior to shipment.</p> <p>_____ F—number of weeks after firm order.</p> <p>_____ D—number of weeks after receipt of approved drawings.</p> <p>Vendor _____</p> <p>Date _____ Vendor Reference _____</p> <p>Signature _____</p> <p>(Signature acknowledges receipt of all instructions)</p>
--

Table G-2 Description

1. Certified general arrangement outline drawing and list of connections, including the following:
  - a. Size, rating and location of all customer connections.
  - b. Approximate overall handling weights.
  - c. Overall dimensions.
  - d. Dimensions of mounting plates and locations of bolt holes for hardware installation.
  - e. Maintenance and disassembly clearances.
  - f. List of reference drawings.
2. Cross-sectional drawings and bill of materials, including the following:
  - a. Machine-mounted sensors and probe holders.
  - b. Vendor supplied extension cables and connectors.
  - c. Monitor rack assemblies.
  - d. List of reference drawings.
3. Control and electrical system schematics and wiring diagrams and bills of materials for all systems. The schematics shall show all adjustment points for alarm and shutdown limits (setpoints).
4. Electrical and Instrumentation arrangement plans for all systems (see Appendix H for typical arrangement plans). The following information shall be provided for all system parts:
  - a. Description.
  - b. Machinery protection system vendor part number.
  - c. Machinery protection system vendor name.
5. System grounding plan.
6. Calibration curves including the following:
  - a. Calibration curves for each shaft radial vibration transducer, casing vibration transducer, shaft axial position transducer, bearing temperature transducer, piston rod drop transducer and machine over-speed transducer showing sensor linearity within specified tolerances (see Section 7.6, Figure 21 and Table 3-A). The machinery protection system vendor's serial/ model number for all transducers, and the target material used for calibrating shaft radial vibration transducers and shaft axial position transducers shall be included on the calibration data.

- b. Electrical and mechanical run-out test data at sensor mounting locations for shaft radial vibration proximity transducers. The run-out data shall be phase related to the permanent or temporary once per revolution marker.
7. Rotor nodal analysis data showing the location of the predicted nodal points relative to the bearing centerlines and the radial shaft vibration probes.
8. Alarm (alert) and shutdown (danger) setpoints for radial shaft vibration, casing vibration, shaft axial position, bearing temperature, piston rod drop and machine overspeed as recommended by the machinery vendor. The limits shall be stated in terms of the monitor display, For example: unfiltered mils peak-to-peak, g's peak or ips peak.
9. Data sheets.
10. Dimensions (including nominal dimensions with design tolerances) and data for the following parts:
  - a. Special transducers.
  - b. Special mounting fixtures.
11. Installation manual describing the following:
  - a. Storage procedure.
  - b. Mounting details.
  - c. Wiring connections.
  - d. Installation and calibration instructions.
  - e. Data sheets.
  - f. Special weather protection and winterization requirements.
  - g. Special system integrity protection requirements.
12. Operating and maintenance manual including the following:
  - a. Wiring connections.
  - b. Installation and calibration instructions.
  - c. Special weather protection and winterization requirements.
  - d. Board level troubleshooting instructions.
  - e. Basic operation details.
  - f. Alarm (alert) and shutdown (danger) setpoint adjustments.
  - g. System bypass operation.
13. Parts list and recommended spares with stocking level recommendations.
14. Progress report and delivery schedule, including vendor buy-outs and milestones.
15. List of all vendor drawings and data, including titles, drawing/ document numbers, schedule for transmission, and latest revision number and dates.
16. Shipping list, including all major components that will ship separately.
17. Statement of any special weather protection and winterization required for startup, operation, and idleness.
18. Special requirements or restrictions necessary to protect the integrity of the machinery protection system.
19. List of special tools furnished for maintenance. Any metric items shall be identified.
20. Technical data manual, including the following:
  - a. Storage procedures.
  - b. Calibration data, per Item 6 above.
  - c. Drawings, in accordance with 8.3.2.
  - d. Tagging information.
  - e. Spare parts list, in accordance with Item 13 above.
  - f. Utility data (power source and purge requirements).
  - g. Machinery protection system field test documentation, including: installation and calibration details, curves and data, rotor mechanical and electrical runouts, and recommended alarm (alert) and shutdown (danger) setpoints.
  - h. Rotor nodal points, in accordance with Item 7 above.
  - i. As-built datasheets, per Item 9 above.
  - j. Machinery protection system integration test results.
21. Material Safety Data Sheet (OSHA Form 20), as applicable.



## APPENDIX H—TYPICAL SYSTEM ARRANGEMENT PLANS

**H.1** This appendix presents typical system arrangements for turbomachinery with hydrodynamic bearings including a turbine (Figure H-1), a double-helical gear (Figure H-2), a centrifugal compressor or pump (Figure H-3), and an electric motor (Figure H-4). A typical arrangement for a pump with rolling element bearings is included as Figure H-5. Figure H-6 shows a typical arrangement for a horizontal reciprocating compressor.

**H.2** As a minimum, the arrangement plan furnished for each machinery train (see Table G-2) shall illustrate the following items on the typical system arrangements:

a. The position of each probe in relation to the machine bearing.

Note: The direction of shaft rotation does not affect the X and Y probe location. The X and Y probes are always located as defined in 6.1.1.1. For piston rod drop probes, refer to note following 6.1.3.6 for probe nomenclature conventions.

b. The machine direction of active thrust (where applicable).  
c. The machine direction of rotation. This shall be accomplished viewing all drivers from the high-pressure or outboard end, and all driven machines from the driven end.

d. A complete description of the system, including the following items, as well as any other information applicable to the layout of the particular system:

1. The number, type, and position of probes.
2. The type of bearings.
3. The clock position of radial probes, with degrees referenced to the vertical top dead center (TDC) as zero.
4. The clock position of phase reference probes, with degrees referenced to the vertical TDC as zero.
5. The location of axial probes.
6. The arrangement of the machine and junction boxes.

e. The layout of the radial shaft vibration, axial position, casing vibration, tachometer, overspeed detection, rod drop, and temperature monitors and all machine signal locations on the monitor.

f. The type of machine.

g. The owner's machine identification number.

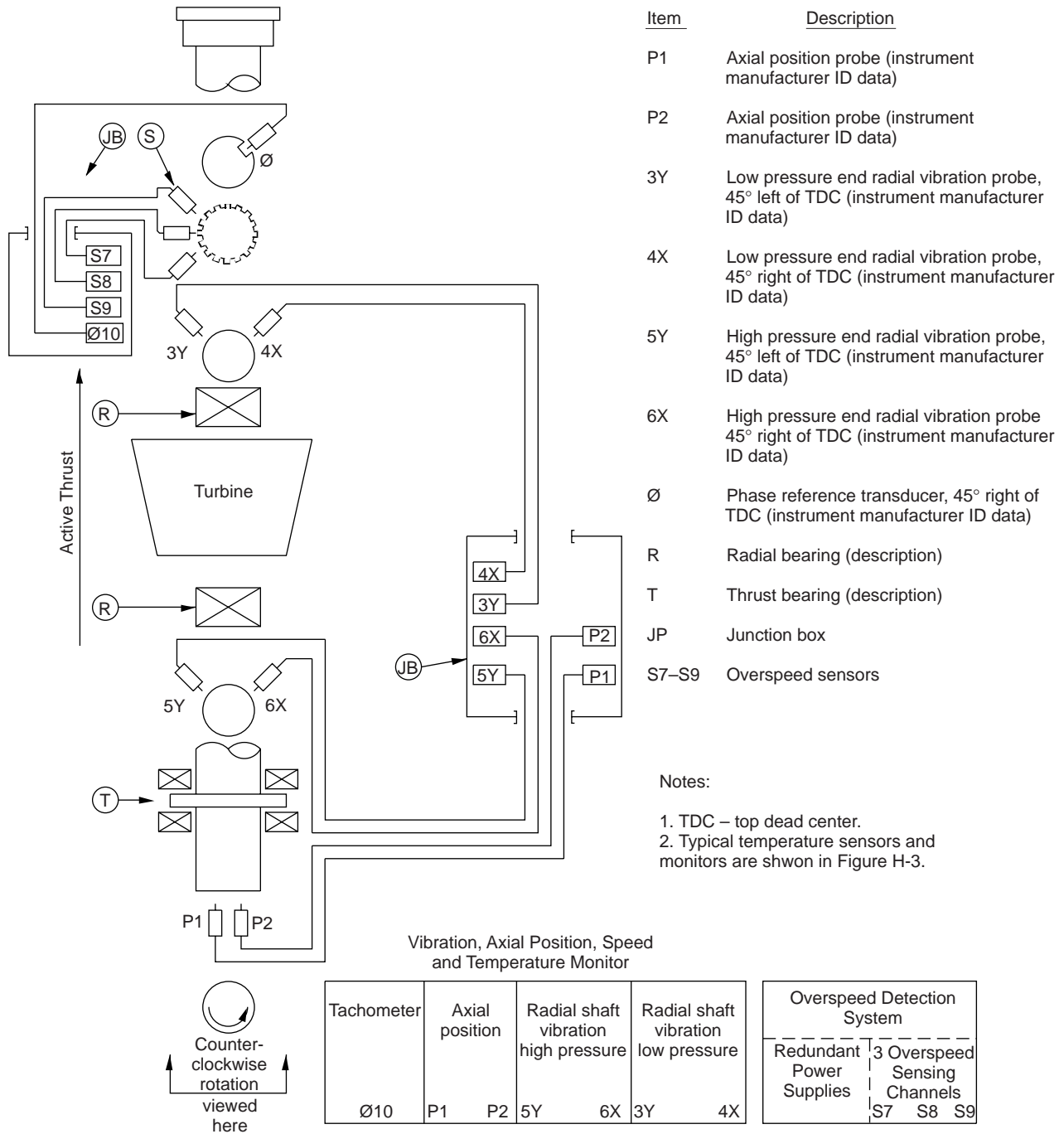
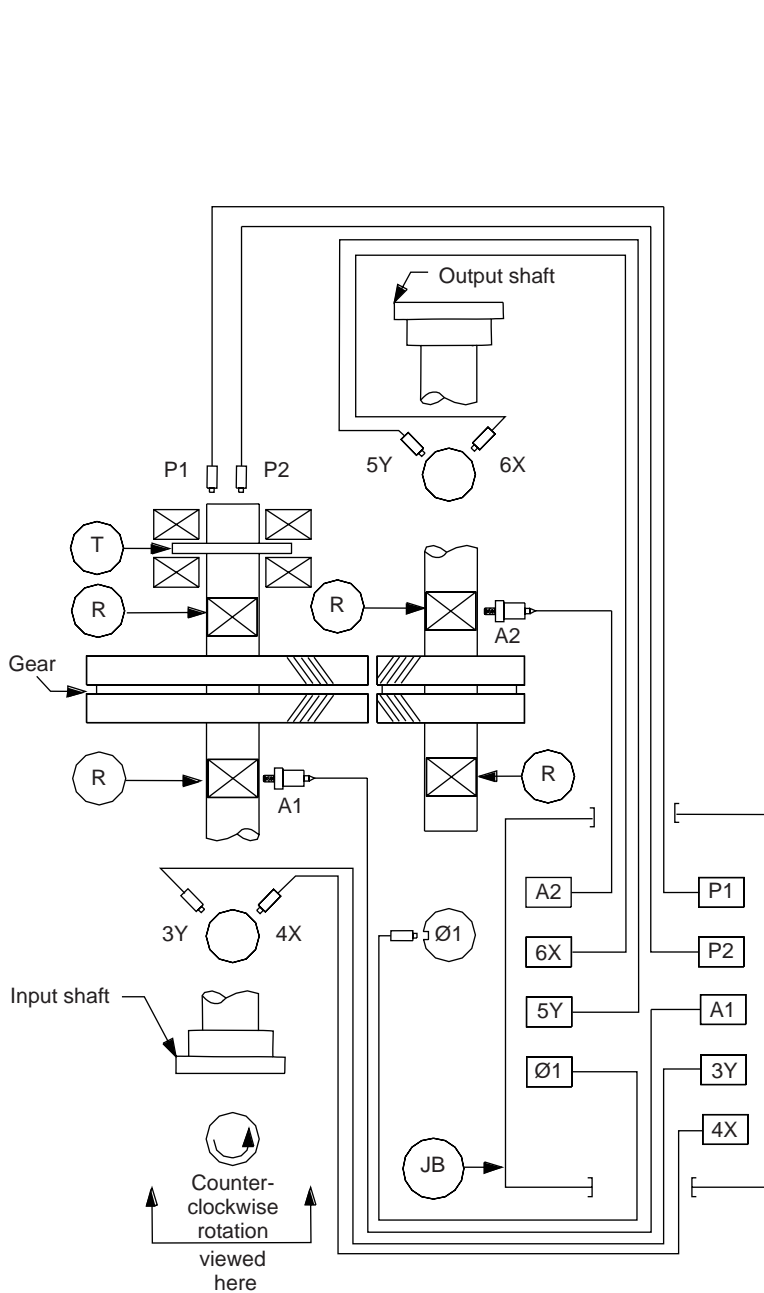

Figure H-1—Typical System Arrangement for a Turbine With Hydrodynamic Bearings



Item	Description
3Y	Input shaft coupling end Y radial vibration probe, 45° left of TDC (instrument manufacturer ID data)
4X	Input shaft coupling end X radial vibration probe, 45° right of TDC (instrument manufacturer ID data)
A1	Input shaft coupling end horizontal radial accelerometer, 90° off TDC (instrument manufacturer ID data)
P1	Input shaft thrust bearing end axial position probe #1 (instrument manufacturer ID data)
P2	Input shaft thrust bearing end axial position probe #2 (instrument manufacturer ID data)
A2	Output shaft coupling end horizontal radial accelerometer, 90° off TDC (instrument manufacturer ID data)
5Y	Output shaft coupling end Y vibration probe, 45° left of TDC (instrument manufacturer ID data)
6X	Output shaft coupling end X radial vibration probe, 45° right of TDC (instrument manufacturer ID data)
Ø1	Output shaft noncoupling end phase reference probe, 90° left of TDC (instrument manufacturer ID data)
R	Radial bearing (description)
T	Thrust bearing (description)
JB	Junction Box

Notes:

1. TDC = top dead center.
2. For a single-helical gear, a pair of axial probes should be installed at each thrust-bearing end.
3. Typical temperature sensors and monitors are shown in Figure H-3.

Vibration, Temperature and Axial Position Monitor

Radial shaft vibration (input shaft)		Bearing cap vibration (input shaft)	Axial shaft position		Radial shaft vibration (output shaft)		Bearing cap vibration (output shaft)
3Y	4X	A1	P1	P2	5Y	6X	A2

Figure H-2—Typical System Arrangement for a Double-Helical Gear

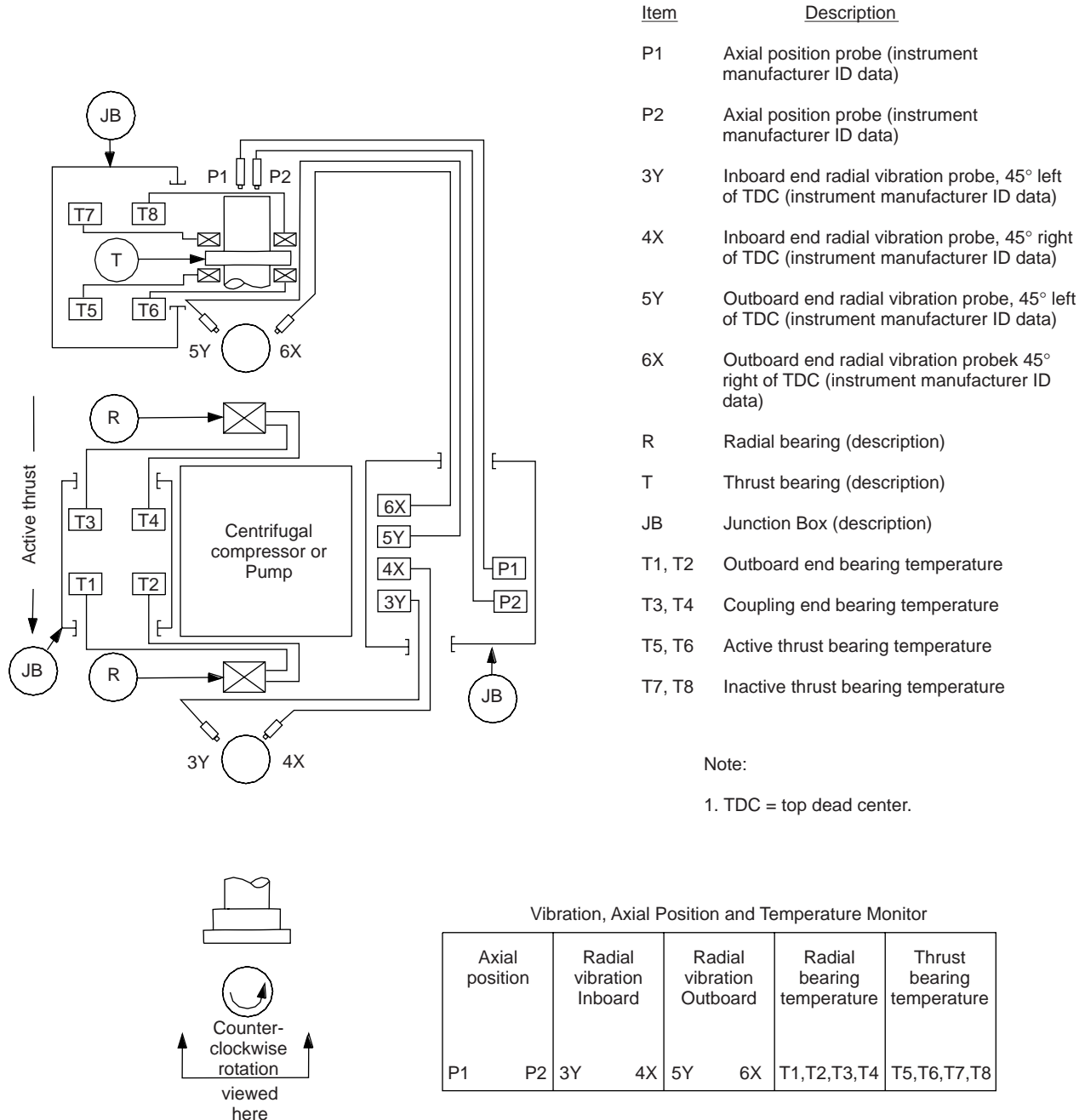
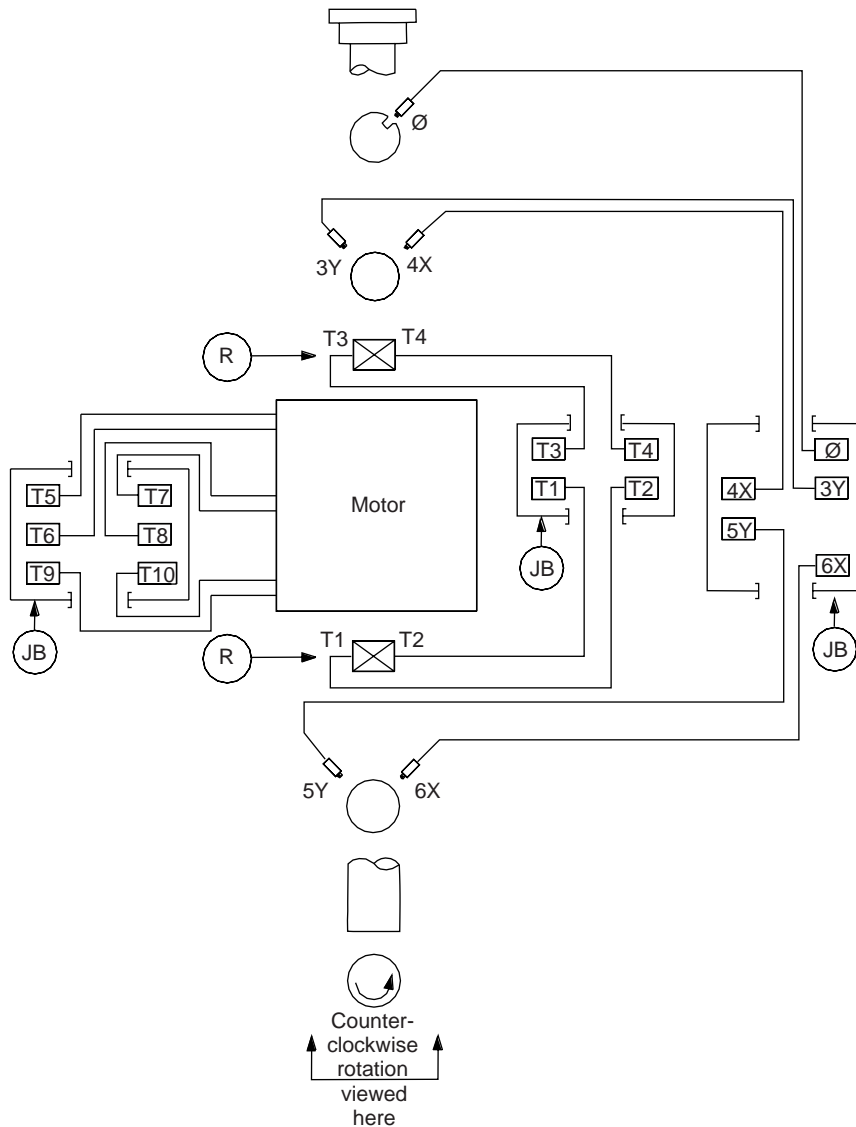

Figure H-3—Typical System Arrangement for a Centrifugal Compressor or a Pump With Hydrodynamic Bearings



Item	Description
5Y	Outboard end Y radial vibration probe, 45° left of TDC (instrument manufacturer ID data)
6X	Outboard end X radial vibration probe, 45° right of TDC (instrument manufacturer ID data)
3Y	Inboard end Y radial vibration probe, 45° left of TDC (instrument manufacturer ID data)
4X	Inboard end X radial vibration probe, 45° right of TDC (instrument manufacturer ID data)
Ø	Phase reference probe, 45° right of TDC (instrument manufacturer ID data)
T1, T2	Outboard end bearing temperature
T3, T4	Inboard end bearing temperature
R	Radial bearing (description)
JB	Junction box (description)
T5, T6	Motor winding temperature (phase A)
T7, T8	Motor winding temperature (phase B)
T9, T10	Motor winding temperature (phase C)

Note:  
1. TDC = top dead center.

Vibration and Temperature Monitor

Radial shaft vibration (Outboard)	Radial shaft vibration (coupling end)	Bearing temperature	Motor Winding Temperature
5Y 6X	3Y 4X	T1,T2,T3,T4	T5,T6,T7, T8, T9, T10

Figure H-4—Typical System Arrangement for an Electric Motor With Sleeve Bearings

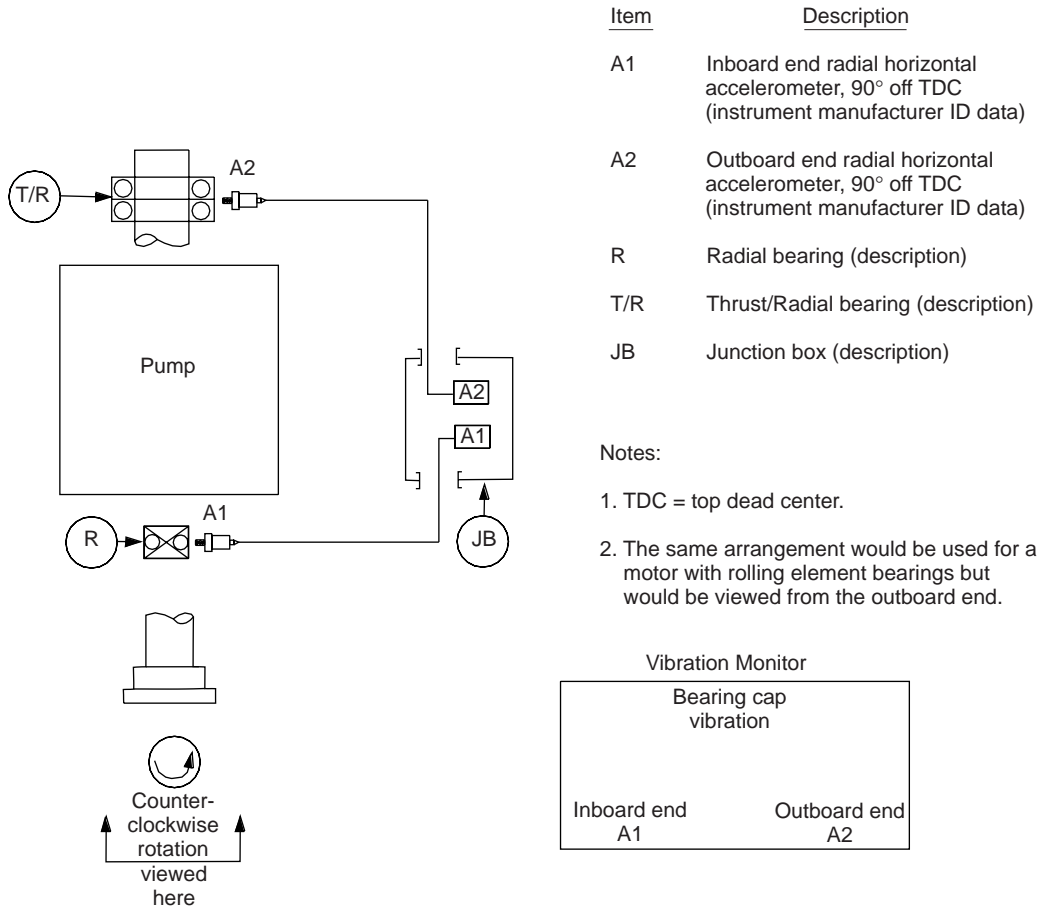
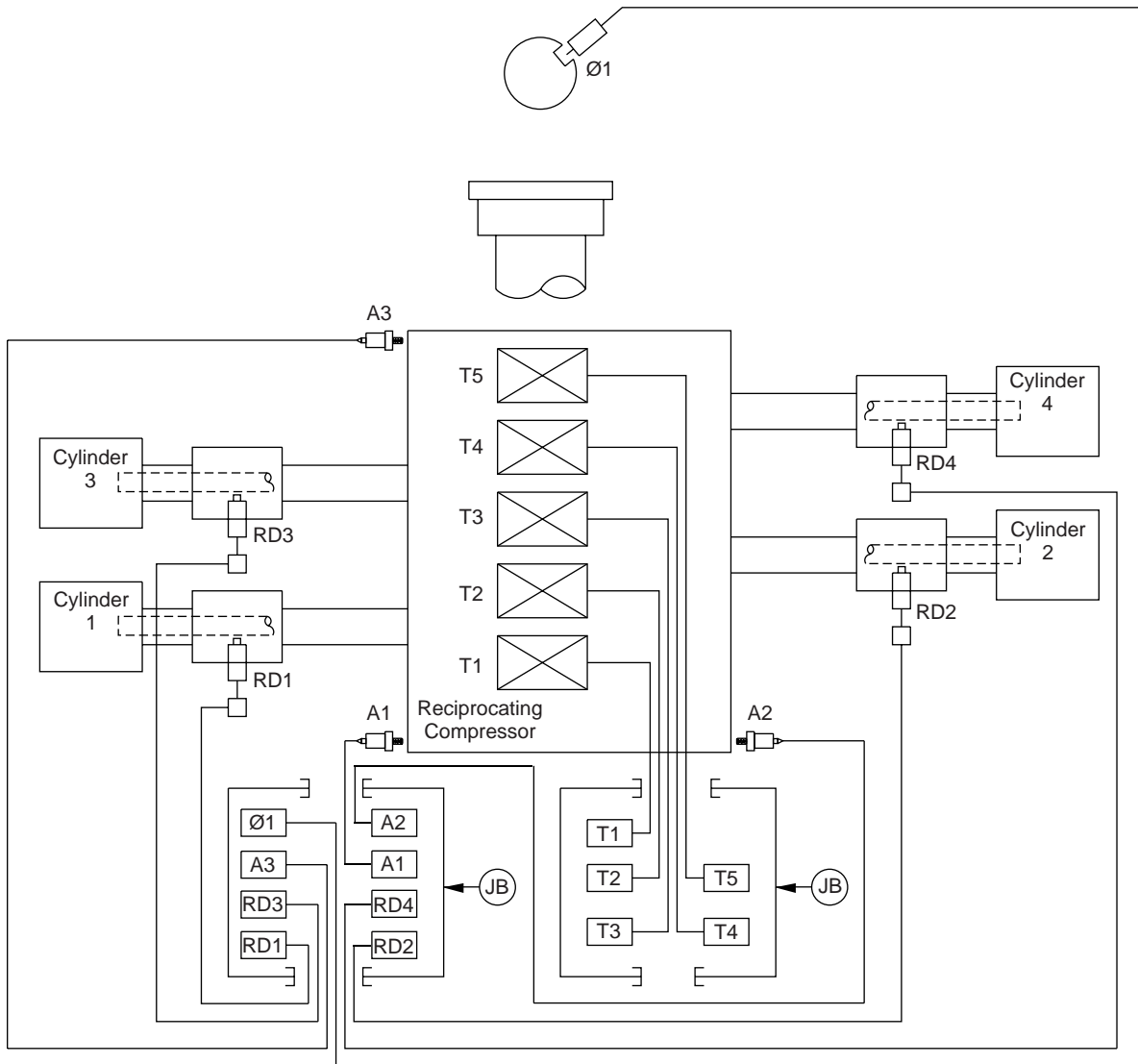

Figure H-5—Typical System Arrangement for a Pump or Motor With Rolling Element Bearings



- | Item     | Description                                       |
|----------|---|
| Ø1       | Phase reference transducer                        |
| R        | Radial Bearing (description)                      |
| JB       | Junction Box (description)                        |
| T1-T5    | Main bearing temperatures                         |
| RD1-RD4  | Rod drop probes (instrument manufacturer ID data) |
| A1,A2,A3 | Casing accelerometers                             |

Rod Drop, Vibration and Bearing Temperature Monitor System

Piston Rod Drop Channels	Casing Vibration Channels	Bearing Temperature Channels
RD1,RD2,RD3,RD4	A1,A2,A3	T1,T2,T3,T4,T5

Figure H-6—Typical System Arrangement for a Reciprocating Compressor





## APPENDIX I—SETPOINT MULTIPLIER CONSIDERATIONS

### I.1 General

**I.1.1** Setpoint multiplication is the function whereby selected channels in the monitor system have their alarm (alert) and shutdown (danger) setpoints elevated by some preset amount (usually an integer multiple such as 2 or 3).

**I.1.2** Setpoint multiplication is usually invoked by an external contact closure (such as a turbine control system relay output). However, this command could also be invoked via a digital communication link on some machinery protection systems.

**I.1.3** This appendix provides an explanation of why this feature may be required on some machine types, and also offers guidance for the proper use of this feature.

Note: Alarm setpoints can vary depending on the strategy and requirements of various users for machinery protection. In some cases, alarm levels are established very close to the mechanical clearance limits of the machine. In these cases, setpoint multiplication should not be specified because it will result in alarm levels that exceed these mechanical clearances and will not provide adequate machinery protection.

### I.2 Fundamental Rotor Response

All rotating machinery exhibits characteristic resonances at certain excitation frequencies. The most common form of excitation is the rotor's own unbalance forces occurring at the rotational speed of the machine. This discussion assumes excitation caused by these unbalance forces.

When a machine's rotational speed coincides with one of its resonances (such as during startup or shutdown), vibration can result that is far above the levels expected at rated running speeds.

Machinery designers are generally careful to account for these resonances in their rotor dynamic designs such that the machine does not operate at or near any resonances.

#### I.2.1 TYPES OF RESPONSES AT RESONANCE CONDITIONS

Vibratory response at resonance conditions can be lateral (that is, radial vibration), axial, or torsional. This standard does not address either axial vibration or torsional vibration measurements as part of the machinery protection system. Therefore, this discussion focuses only on the lateral or radial vibration response as measured by proximity probes or by casing transducers such as accelerometers. However, care should be taken to recognize and document resonance responses other than radial vibration because they can be just as damaging to the machine.

### I.2.2 OPERATION ABOVE THE FIRST CRITICAL SPEED

**I.2.2.1** For machines that operate at rotational speeds above their first critical, it is necessary for the machine to pass through one or more resonances as it ramps up or ramps down. Figure I-1 shows a typical radial vibration amplitude response of a machine operating above its first critical but below its second critical. The first critical occurs at the speed designated as  $rpm_{critical}$  in Figure I-1. The vibration amplitude at this rotational speed is shown as  $amp_{critical}$ . While this figure shows only the response from a single measurement location on the machine, similar graphs can be constructed for each radial vibration measurement location.

**I.2.2.2** The machine's rated rotational speed is designated as  $rpm_{rated}$  and the radial vibration amplitude occurring at this speed is designated as  $amp_{rated}$ . At this rated running speed, the vibration amplitude  $amp_{rated}$  is less than the normal Alert ( $A_{norm}$ ) and Danger ( $D_{norm}$ ) setpoints.

### I.3 Conditions Requiring Setpoint Multiplication

**I.3.1** Notice that the machine in Figure I-1 experiences vibration amplitudes in excess of its normal alarm (alert) and shutdown (danger) setpoints when it passes through its first critical. If the machine remains in this speed region ( $rpm_1 \leq \text{speed} \leq rpm_2$ ) for a time  $\Delta_t$  that exceeds the preset alarm delays for the channel, alarm (alert) or shutdown (danger) events will result. In the case of a danger event, this may actually result in the machine being shut down even though it was merely experiencing normal vibration responses as it passed through a resonance.

**I.3.2** The condition defined in I.3.1 leads to the need for setpoint multiplication. As shown in Figure I-1, if the alarm (alert) and shutdown (danger) setpoints are multiplied by a factor of 3 while the machine is operating between rotational speeds  $rpm_1$  and  $rpm_2$ , the machine can pass through its first critical without encountering spurious alarms. In this case, the alarm (alert) and shutdown (danger) setpoints are elevated temporarily to  $A_{mult}$  and  $D_{mult}$  respectively. The setpoints return to their normal levels when the machine is outside this speed region.

**I.3.3** Thus, setpoint multiplication is required when both the criteria below are met:

a. The machine experiences vibration amplitudes in excess of its danger or alert setpoints as it passes through a machine

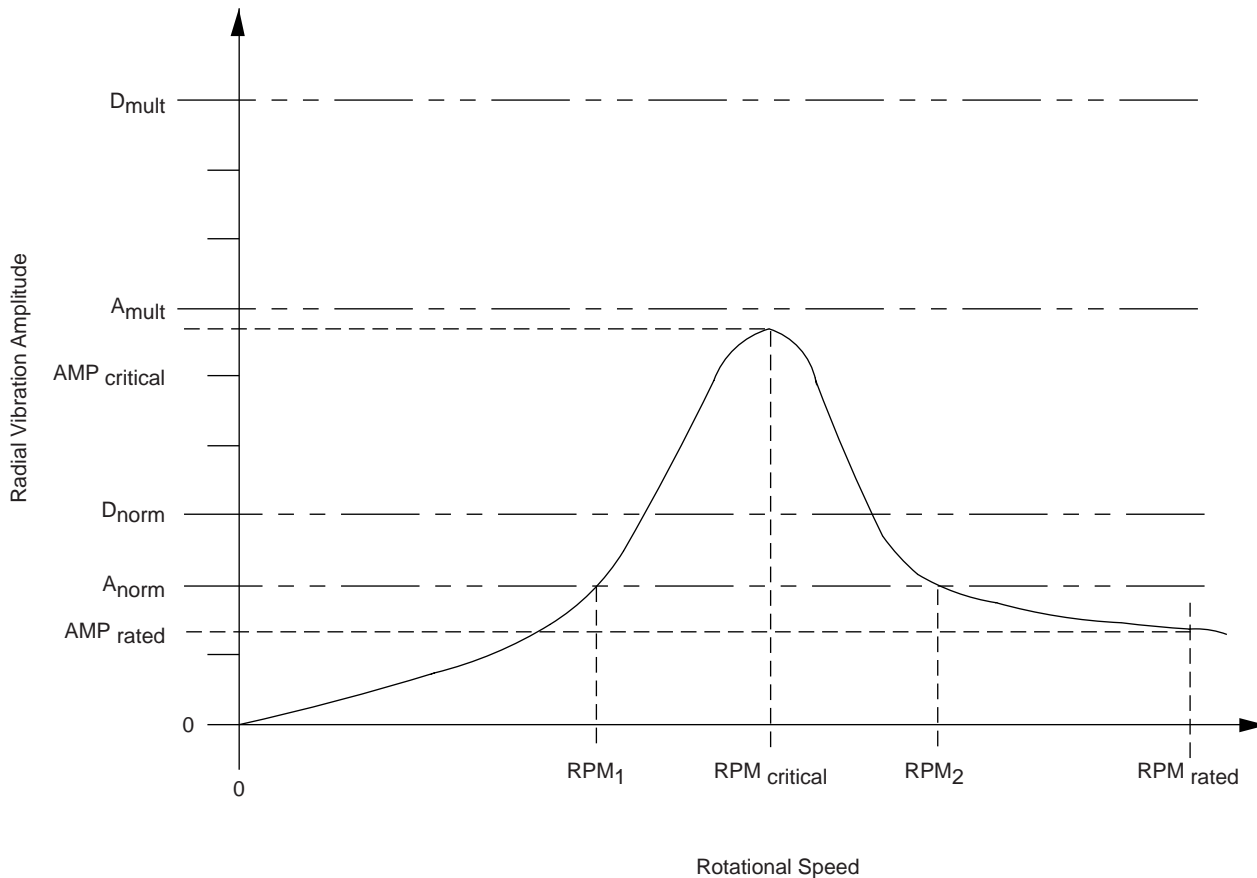

Figure I-1—Setpoint Multiplication Example

resonance and this results in unwanted machine shutdown or alarms; and,

b. The duration of this setpoint violation exceeds the preset alarm delay times.

#### I.4 Alarm Suppression or Bypass Considerations

The practice of bypassing or suppressing the machinery protection system alarms while it passes through a resonance in lieu of using properly established setpoint multiplication functions is strongly discouraged. Setpoint multiplication merely elevates the alarms, it does not suppress them. This ensures that machinery protection is provided at all rotational speeds of the machine.

#### I.5 Proper Applications of Setpoint Multiplication

The proper application of the setpoint multiplication function can be divided into 2 basic considerations.

##### I.5.1 PROPER IDENTIFICATION OF APPLICABLE CHANNELS

Each radial vibration location will typically measure a different amplitude response. Thus, the machine's characteristic response at each radial vibration measurement location should be documented over the range of rotational speeds from zero to rated speed. This information should be used in determining which channels require setpoint multiplication. Only those channels which meet the criteria of I.3.3.a and I.3.3.b above should be fitted with setpoint multiplication functions.

##### I.5.2 PROPER SELECTION OF SETPOINT MULTIPLIERS

The characteristic response for each measurement location documented in I.5.1 above should also be used to establish the appropriate multiplier. The multiplier should generally be chosen to be as small as possible while still elevating the alarm (alert) and shutdown (danger) setpoints to levels that are above the machine's characteristic response at resonance.

Provisions for setpoint multiplication by 2 or 3 are required of machinery protection systems complying with this standard (the example contained in Figure I-1 assumes an integer multiple of 3 as can be noted by the tic marks on the vertical axis). When multipliers in excess of 3 are required to accommodate the machine's response at resonance(s), this may be indicative of machinery that has unacceptably large amplification factors. The machinery manufacturer should be consulted.

## **I.6 Control System Interface Considerations**

Typically, the machine control system will be capable of generating an output signal, such as a relay contact closure, that is wired to the machinery protection system to invoke its setpoint multiplication function. There are three basic ways this is accomplished.

### **I.6.1 ABSOLUTE SPEED RANGE SENSING**

This method requires the machine control system to sense the rotational speed of the machine and activates an output any time the machine is operating at speeds between  $\text{rpm}_1$  and  $\text{rpm}_2$ .

### **I.6.2 TIMER**

This method can be used if the acceleration and deceleration rates of the machine are repeatable. In this case, a preset timer in the machine control system is triggered whenever the machine is accelerating through speed  $\text{rpm}_1$  or decelerating through speed  $\text{rpm}_2$ . The machine control system simply

invokes the setpoint multiplication output for a time equal to or greater than  $\Delta_t$  (refer to I.3 for a discussion of  $\Delta_t$ ).

Note: The duration  $\Delta_t$  is dependent on the acceleration and deceleration rates governed by the machine control system. This paragraph should not be construed as permitting the machine to dwell indefinitely at or near its critical speed(s).

### **I.6.3 MANUAL OPERATION**

This method does not rely on an automatic machinery control system. Instead, an operator manually invokes the setpoint multiplication in the machinery protection system by a pushbutton or switch or timer as part of the machine startup or shutdown procedure. However, this is rarely encountered because most machines are now fitted with automatic control systems capable of performing all startup and shutdown control and sequencing without human intervention.

### **I.6.4 BEST PRACTICE RECOMMENDATIONS**

The method described in I.6.1 above is encouraged as best practice when integrating the machine control system with the machinery protection system. The manual method described in I.6.3 is least desirable because it relies on human intervention for proper machinery protection. It can result in false trips or alarms if the setpoint multiplication function is not invoked. It can also lead to missed trips or alarms if the setpoint multiplication function remains invoked even though the machine is operating outside the region between  $\text{rpm}_1$  and  $\text{rpm}_2$ .



## APPENDIX J—ELECTRONIC OVERSPEED DETECTION SYSTEM CONSIDERATIONS

### J.1 General

**J.1.1** The standard employed for the rotating machine under consideration will generally specify the allowable momentary overspeed as a percent of rated operating speed. For example, API 612 requires the overspeed protection system to preclude the rotor from ever exceeding 127% of the rated operating speed on mechanical drives, and 121% on generator drives.

**J.1.2** The electronic overspeed detection system is only one component within the entire overspeed protection system (see Figure J-1). The performance of the entire system is not limited to items discussed in this standard. Other components which are critical in determining the response of the entire system may include, but are not limited to: interposing relays, solenoids, trip valve(s), non-return valves, steam and hydraulic piping, and the entrained energy within the rotating

machine itself. Collectively, these components comprise the overspeed protection system.

### J.2 System Response Time

This standard requires that the electronic overspeed detection system be able to detect an overspeed event and change the state of its output relays within 40 milliseconds when provided with an input signal frequency of at least 300 Hz. However, this response time of the detection system alone does not guarantee that the complete overspeed protection system will be suitable for a particular application. Other system dynamics need to be considered. Proper engineering judgment and system design must be used to ensure that the complete overspeed protection system functions properly and responds fast enough to preclude the rotor speed from exceeding the maximum allowable limit. Consult ASME PTC 20.2-1965 Section 5 as an example of how to evaluate the total system response time.

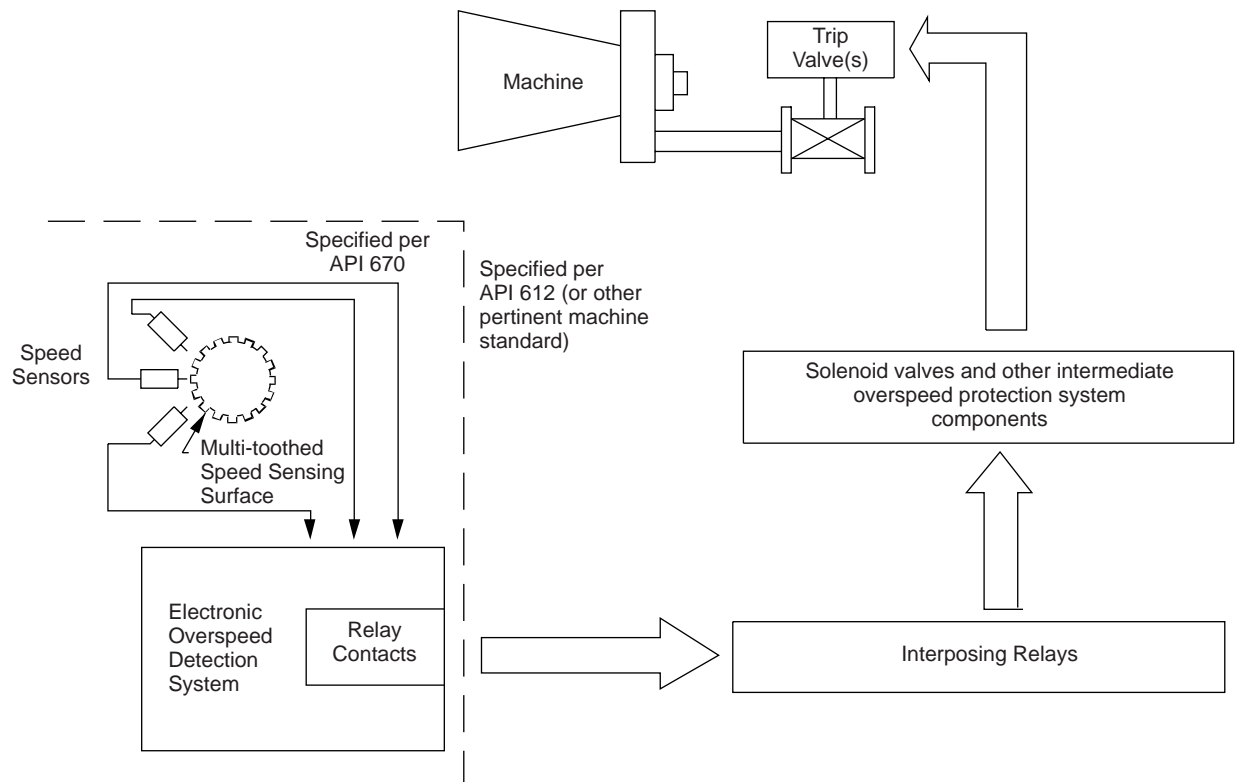

Figure J-1—Overspeed Protection System

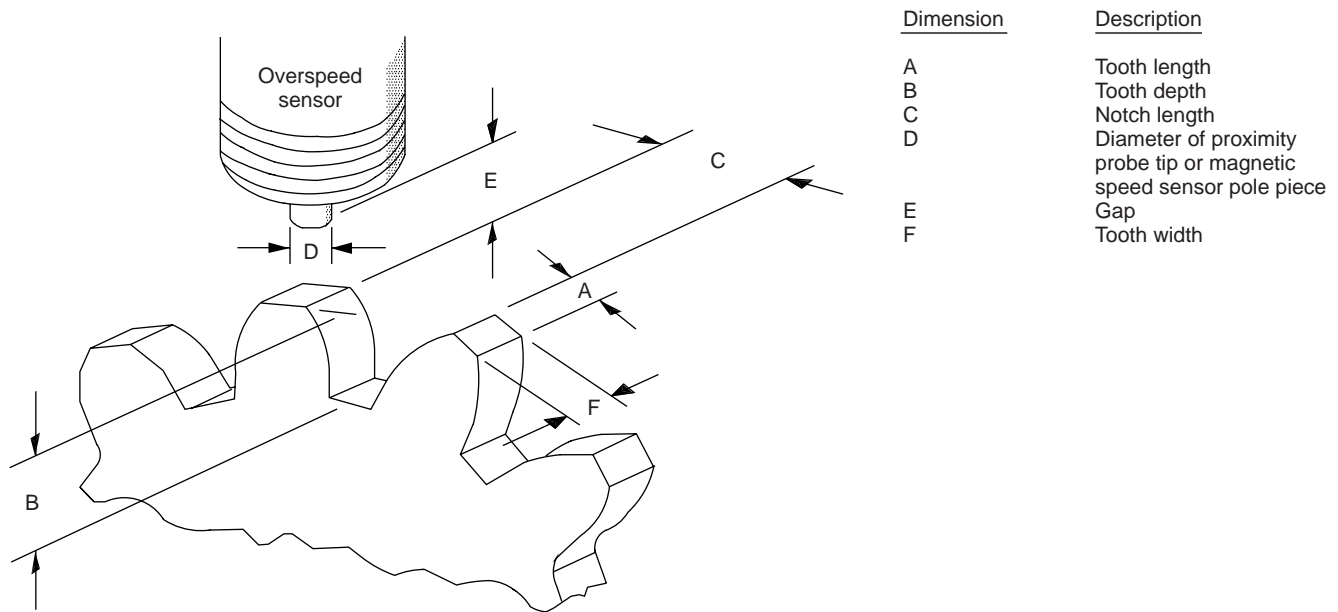

Figure J-2—Relevant Dimensions for Overspeed Sensor and Multi-Tooth Speed Sensing Surface Application Considerations (See Table J-1)

### J.3 General Considerations for Multi-Toothed Speed Sensing Surfaces

The speed sensing surface may be a gear, toothed wheel, evenly spaced holes in a shaft surface, or other such target that provides gap discontinuities for the speed sensors to observe. Characteristics of the sensing surface will need to be matched to the sensor type to ensure the input signal amplitude to the electronic overspeed detection system is within allowable minimum and maximum voltage limits. Figure J-2 shows the dimensions of the speed sensor and multi-tooth speed sensing surface that are relevant to application considerations.

When designing or installing a multi-toothed speed sensing surface, care should be taken to ensure that differential axial movement will not cause the speed sensing surface to move outside the transducer's range. The machine may expand or contract due to thermal conditions and normal rotor axial float. Precautions can be taken to address the expansion and contraction characteristics. The speed sensing surface should be of suitable thickness or may be located in an area not subject to excessive axial expansion or contraction of the shaft or the surface to which the speed sensor is affixed.

#### J.3.1 SPEED SENSING SURFACE FOR MAGNETIC SPEED SENSORS

**J.3.1.1** When magnetic speed sensors are used, the optimum dimensions of the speed sensing surface are a function of the pole piece diameter ( $D$ ). Refer to Table J-1 for recom-

mended dimensions when this arrangement is used. However, additional calculations are required to ensure optimum signal strength for the electronic overspeed detection system inputs. Some of these additional calculations include, but are not limited to, surface speed, gear pitch, air gap, and load. Consult the magnetic speed sensor manufacturer to ensure correct application guidelines are observed.

**J.3.1.2** Installation considerations require a thorough understanding of the peak-to-peak vibration characteristics at the speed sensing location during both running speed and overspeed conditions. Magnetic speed sensors require a close gap, typically less than 0.51 mm (20 mils), for optimal operation. This may allow the observed speed sensing surface to contact the sensor during high radial vibration conditions, causing loss of signal and failure of the sensor. Applications in which the speed sensing surface is subject to high radial vibration amplitudes (particularly during an overspeed event) should consider the use of proximity probes as detailed in Sections J.3.2 and J.3.3.

#### J.3.2 NON-PRECISION SPEED SENSING SURFACE FOR PROXIMITY PROBES

A non-precision speed sensing surface employs tooth depths that exceed the proximity probe's linear operating range (see Figure J-3). While proximity probes do not necessarily have to be used with a precision-machined speed sensing surface (see Section J.3.3 below), that arrangement is

recommended to achieve the best possible diagnostic capabilities on the speed sensor inputs. When a non-precision speed sensing surface is employed with proximity probe speed sensors, refer to Table J-2 for recommended dimensions.

**J.3.3 PRECISION-MACHINED SPEED SENSING SURFACE FOR PROXIMITY PROBES**

A precision-machined toothed wheel employs a precise tooth depth to keep a proximity probe system within its lin-

ear operating range at all times (see Figure J-4). This arrangement permits enhanced circuit fault detection and diagnostic capabilities beyond those achievable when speed sensors are used as detailed in Sections J.3.1 and J.3.2 above. In addition, this arrangement is capable of providing an OK sensor indication while the machine is not running. Refer to Table J-3 for recommended dimensions when using this arrangement.

**Table J-1—Recommended Dimensions for Speed Sensing Surface When Magnetic Speed Sensors are Used**

Dimension	Recommended
A (tooth length)	≥ D
B (tooth depth)	≥ C
C (notch length)	≥ 3D
D (diameter of pole piece)	Typically 4.749 mm (0.187 in.).
E (gap)	As close as possible. Typically 0.254 mm (10 mils) or less.
F (tooth width)	≥ D

**Table J-2—Recommended Dimensions for Non-Precision Speed Sensing Surface When Proximity Probe Speed Sensors are Used<sup>1</sup>**

Dimension	Minimum	Nominal	Maximum
A (tooth length)	8 mm	Unlimited <sup>2,3</sup>	Unlimited <sup>2,3</sup>
B (tooth depth)	2 mm	Unlimited	Unlimited
C (notch length)	8 mm	Unlimited <sup>2,3</sup>	Unlimited <sup>2,3</sup>
E (gap)	0.5 mm	0.875 mm	1.25 mm
F (tooth width)	8 mm	Unlimited	Unlimited

**Table J-3—Recommended Dimensions for Precision-Machined Speed Sensing Surface When Proximity Probe Speed Sensors are Used<sup>1</sup>**

Dimension	Minimum	Nominal	Maximum
A (tooth length)	8 mm	Unlimited <sup>2,3</sup>	Unlimited <sup>2,3</sup>
B (tooth depth) <sup>4</sup>	1 mm	1 mm	1.3 mm
C (notch length)	8 mm	Unlimited <sup>2,3</sup>	Unlimited <sup>2,3</sup>
E (gap) <sup>4</sup>	0.5 mm	0.65 mm	0.8 mm
F (tooth width)	8 mm	Unlimited	Unlimited

## Notes:

1. Tables J-2 and J-3 assume the use of standard or standard-option proximity probes (see Sections 5.1.1.2 and 5.1.1.3) with a linear range of at least 2.03 mm (80 mils). For applications where non-standard probes are to be used, consult the machinery protection system vendor.
2. Where an unlimited dimension is stated, the actual maximum limit will be determined by the overall diameter of the multi-toothed speed sensing surface and the desired number of events-per-revolution.
3. An unlimited tooth length/notch length is not intended to imply that a speed sensing surface with only a single discontinuity (that is, tooth) is acceptable for overspeed applications. Such a design provides only a one-event-per-revolution signal and is rarely able to achieve the necessary response time required for proper machinery overspeed protection. Unlike a multi-tooth design, it requires multiple revolutions of the rotor to determine the change in rotor speed. The greater the number of events-per-revolution, the higher the resolution of the sampled speed signal.
4. If Dimension B + Dimension E exceeds 1.8 mm (70.9 mils), the probe may indicate a NOT OK condition if the rotor stops with the probe observing a notch.

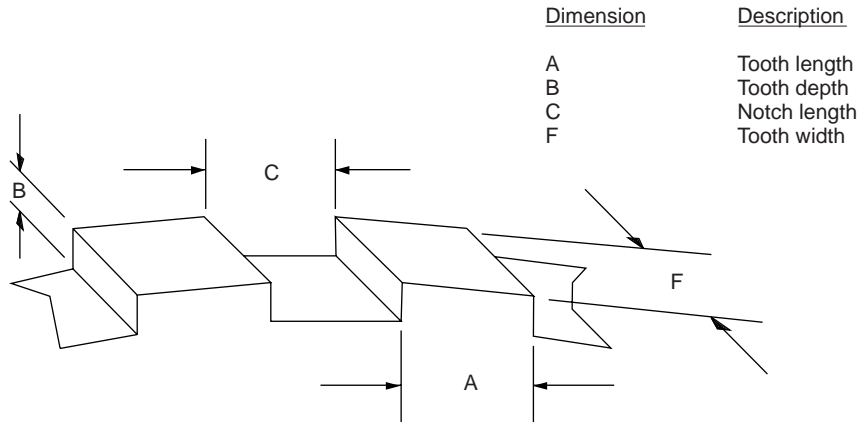

Figure J-4—Precision-Machined Overspeed Sensing Surface  
(See Table J-3)



# American Petroleum Institute

# Publications Order Form - 2000

Available through Global Engineering Documents

Phone Orders: 1-800-854-7179 (Toll-free in the U.S. and Canada) • 303-397-7956 (Local and International) • Fax Orders: 303-397-2740

Online Orders: www.global.ihs.com

Date: \_\_\_\_\_

API Member (Check if Yes)

**Invoice To** ( Check here if same as "Ship To")

Name: \_\_\_\_\_  
 Title: \_\_\_\_\_  
 Company: \_\_\_\_\_  
 Department: \_\_\_\_\_  
 Address: \_\_\_\_\_  
 \_\_\_\_\_  
 City: \_\_\_\_\_ State/Province: \_\_\_\_\_  
 Zip/Postal Code: \_\_\_\_\_ Country: \_\_\_\_\_  
 Telephone: \_\_\_\_\_  
 Fax: \_\_\_\_\_  
 E-Mail: \_\_\_\_\_

**Ship To** (UPS will not deliver to a P.O. Box)

Name: \_\_\_\_\_  
 Title: \_\_\_\_\_  
 Company: \_\_\_\_\_  
 Department: \_\_\_\_\_  
 Address: \_\_\_\_\_  
 \_\_\_\_\_  
 City: \_\_\_\_\_ State/Province: \_\_\_\_\_  
 Zip/Postal Code: \_\_\_\_\_ Country: \_\_\_\_\_  
 Telephone: \_\_\_\_\_  
 Fax: \_\_\_\_\_  
 E-Mail: \_\_\_\_\_

Quantity	Product Number	Title	SO*	Unit Price	Total
	<b>C61008</b>	<b>Std 610, Centrifugal Pumps for Petroleum, Heavy Duty Chemical and Gas Industry Services</b>		<b>\$ 132.00</b>	
	<b>C61404</b>	<b>Std 614, Lubrication, Shaft-Sealing, and Control-Oil Systems and Auxiliaries for Petroleum, Chemical and Gas Industry Services</b>		<b>\$ 132.00</b>	
	<b>C68201</b>	<b>Std 682, Shaft Sealing Systems for Centrifugal and Rotary Pumps</b>		<b>\$ 116.00</b>	
	<b>C68401</b>	<b>Publ 684, Tutorial on the API Standard Paragraphs Covering Rotor Dynamics and Balance (An Introduction to Lateral Critical and Train Torsional Analysis and Rotor Balancing)</b>		<b>\$ 116.00</b>	
	<b>C68601</b>	<b>RP 686, Machinery Installation and Installation Design</b>		<b>\$ 83.00</b>	

Payment Enclosed     P.O. No. (Enclose Copy) \_\_\_\_\_

Charge My Global Account No. \_\_\_\_\_

VISA     MasterCard     American Express     Discover

Credit Card No.: \_\_\_\_\_

Name (As It Appears on Card): \_\_\_\_\_

Expiration Date: \_\_\_\_\_

Signature: \_\_\_\_\_

<b>Subtotal</b>
<b>Applicable Sales Tax</b> (see below)
<b>Rush Shipping Charge</b> (see below)
<b>Shipping and Handling</b> (see below)
<b>Total</b> (in U.S. Dollars)

**\*To be placed on Standing Order for future editions of this publication, place a check mark in the SO column and sign here:**

**Pricing and availability subject to change without notice.**

**Mail Orders** – Payment by check or money order in U.S. dollars is required except for established accounts. State and local taxes, plus 5% for shipping and handling, must be added. Send mail orders to: **API Publications, Global Engineering Documents, 15 Inverness Way East, M/S C303B, Englewood, CO 80112-5776, USA.**

**Purchase Orders** – Purchase orders are accepted from established accounts. Invoice will include actual freight cost, an \$8.00 handling fee, plus state and local taxes.

**Telephone Orders** – If ordering by telephone, an \$8.00 handling fee and actual freight costs will be added to the order.

**Sales Tax** – All U.S. purchases must include applicable state and local sales tax. Customers claiming tax-exempt status must provide Global with a copy of their exemption certificate.

**Shipping (U.S. Orders)** – Orders shipped within the U.S. are sent via traceable means. Most orders are shipped the same day. Subscription updates are sent by First-Class Mail. Other options, including next-day service, air service, fax transmission, and electronic delivery are available at additional cost.

**Shipping (International Orders)** – Standard international shipping is by air express courier service. Subscription updates are sent by World Mail. Normal delivery is 3-4 days from shipping date.

**Rush Shipping Fee** – In addition to the carrier charges, the following charges will be added: Next Day Delivery orders placed prior to 2:00 p.m. MST - \$10.00 / Next Day Delivery orders placed after 2:00 p.m. MST - \$20.00 (if time is available for order processing)

**Returns** – All returns must be pre-approved by calling Global's Customer Service Department at 1-800-624-3974 for information and assistance. There may be a 15% restocking fee. Special order items, electronic documents, and age-dated materials are non-returnable.

The American Petroleum Institute provides additional resources and programs to industry which are based on API Standards.

For more information, contact:

- Training/Workshops Ph: 202-682-8490  
Fax: 202-962-4797
- Inspector Certification Programs Ph: 202-682-8161  
Fax: 202-962-4739
- American Petroleum Institute  
Quality Registrar Ph: 202-682-8574  
Fax: 202-682-8070
- Monogram Licensing Program Ph: 202-962-4791  
Fax: 202-682-8070
- Engine Oil Licensing and  
Certification System Ph: 202-682-8233  
Fax: 202-962-4739

To obtain a free copy of the API Publications, Programs, and Services Catalog, call 202-682-8375 or fax your request to 202-962-4776. Or see the online interactive version of the catalog on our web site at [www.api.org/cat](http://www.api.org/cat).



Helping You  
Get The Job  
Done Right.<sup>SM</sup>



Additional copies available from API Publications and Distribution:  
(202) 682-8375

Information about API Publications, Programs and Services is  
available on the World Wide Web at: <http://www.api.org>



1220 L Street, Northwest  
Washington, D.C. 20005-4070  
202-682-8000

Order No. C67004